



ALBERTO
SASSI
HIGHER LIFT TECHNOLOGY

CATALOGO
GEARLESS

GEARLESS
CATALOGUE

REV. 2 - 09/2025

S
S
E
A
E
G

I disegni e i dati raccolti nel presente catalogo sono di esclusiva proprietà di Alberto Sassi S.p.A.. La riproduzione, anche parziale, dei suddetti disegni è vietata. I dati riportati sono indicativi e non sono impegnativi. I prodotti presentati possono, in ogni momento e senza preavviso, subire modifiche.

The drawings and data in this catalog are the exclusive property of Alberto Sassi S.p.A.. Reproduction, even partial, of these drawings is forbidden. Entire and/or partial reproduction is prohibited. The data are not binding. The items featured in this catalogue may be changed without previous notice.

MODELLI / MODELS

TABELLA PORTATE DUTY-LOAD TABLE	3
G-200	6
G-300 T0 · TS · TC	14
G-300 T1 · T2	15
G-400	33
G-500	51
G-525	55

ACCESSORI E TELAI / ACCESSORIES AND FRAMES

TELMO	66
TELAJ / FRAMES	68
SCHEDE ELETTRONICHE ELECTRONIC BOARDS	73
TABELLA ACCESSORI ACCESSORIES TABLE	73



TABELLA PORTATE / DUTY-LOAD TABLE

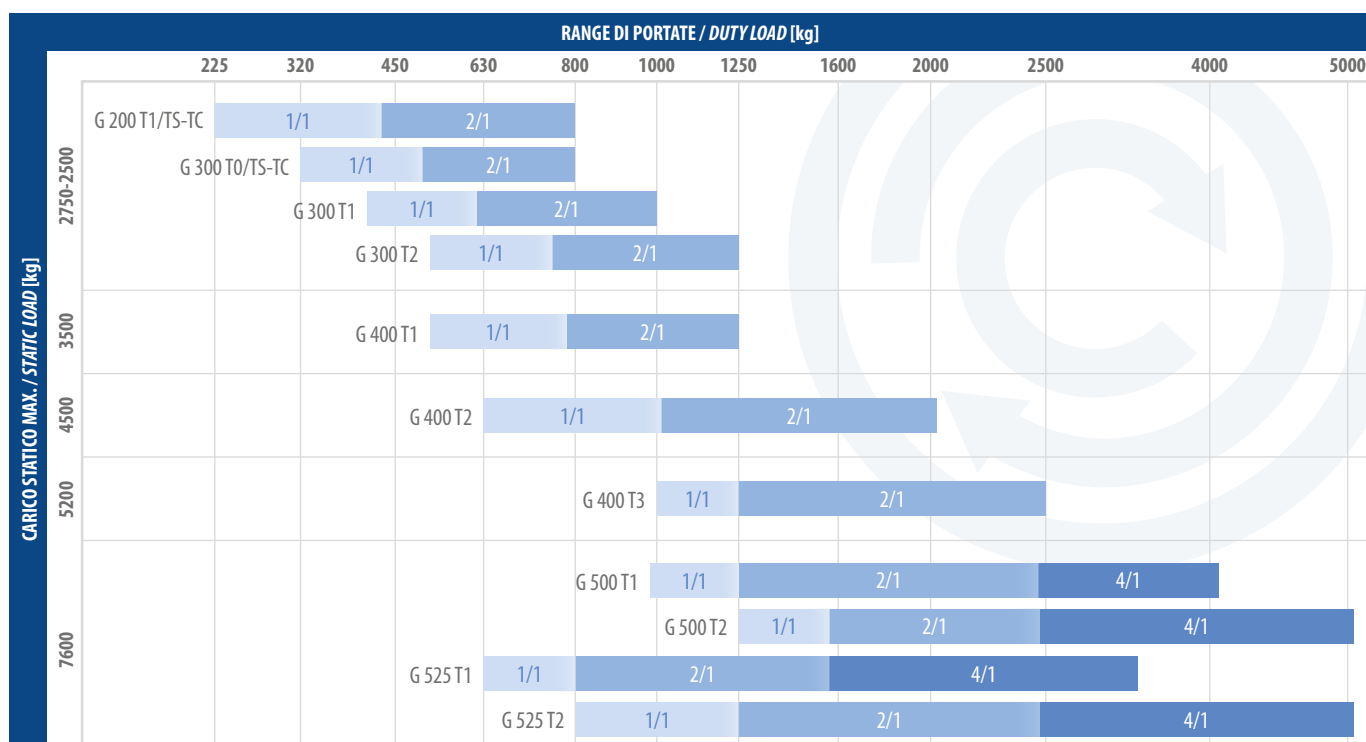

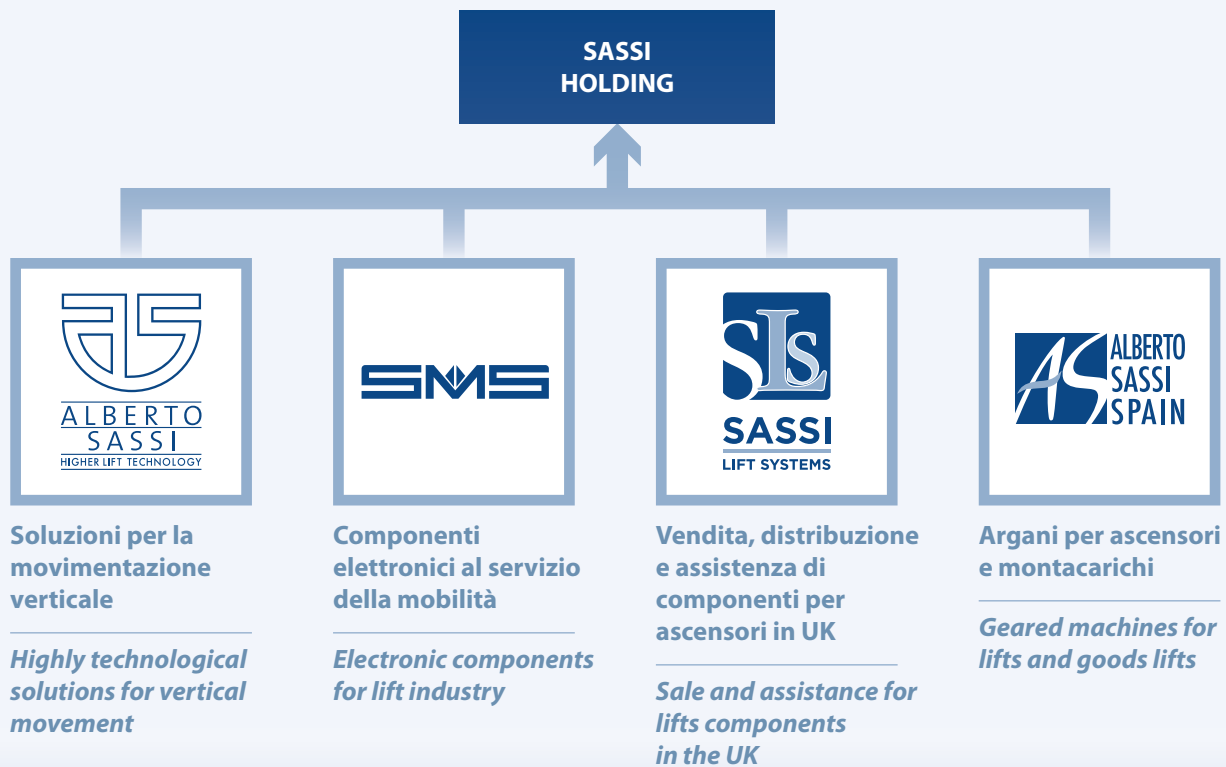

LA NOSTRA MISSION

Bene factum

La nostra azienda nasce da un'intuizione coraggiosa: produrre argani e motori, nel contesto postbellico. Investire in ricerca, sviluppo e persone ci ha portati a diventare leader mondiale nel settore degli argani.

Oggi creiamo sistemi di trazione **Made in Italy** per la mobilità verticale. Domani daremo soluzioni al passo con l'innovazione e i nuovi criteri di sostenibilità ambientale.

Produciamo le tecnologie internamente, testiamo, ci sporchiamo le mani. Lo facciamo pensando all'industria ascensoristica del futuro. Lo faremo un passo alla volta, *fatto bene*.

LA NOSTRA VISION

Un passo alla volta

Ci impegniamo ogni giorno per rendere la Alberto Sassi un ottimo partner con cui collaborare, una bella azienda in cui lavorare, una realtà industriale che pensa al profitto ma anche all'ambiente.

Ascoltare il mercato per portare l'innovazione **Made in Italy** nell'industria ascensoristica globale, è l'obiettivo su cui plasmiamo il nostro futuro.

È un viaggio già iniziato, ma la strada è lunga. È una strada fatta di impegno, sacrifici, investimenti e coraggio. La percorreremo, senza scorciatoie, *un passo alla volta*.

OUR MISSION

Bene factum

Our company owes its origins to courageous intuition: making geared traction machines and motors in post-war Italy. Investing in research, development and human capital has led us to become a world leader in the field of geared machines.

*Today we create traction systems for vertical mobility, all **Made in Italy**. Tomorrow we will be providing solutions abreast with innovation and the new environmental sustainability criteria.*

Our technologies are produced in-house; we test them, ours is a hands-on approach. We do this while focusing on the elevator industry of the future. We will proceed one step at a time, accurately.

OUR VISION

One step at a time

Our daily commitment is to ensure that Alberto Sassi is an excellent partner to do business with, a great company in which to work, an industrial enterprise not only focused on profit but also on the environment.

*Keep ahead of the market trends and make **Made in Italy** innovation a part of the global elevator industry is the goal on which our future will be built.*

The journey has already begun, but the road is long. An undertaking that calls for commitment, sacrifice, investments and courage. We will proceed one step at a time, without taking short-cuts.

Passione al servizio di chi sceglie la nostra **competenza**

Noi i gearless li facciamo così.

Ci prendiamo cura di ogni componente per offrire un prodotto compatibile con le esigenze tecnologiche più complesse.

Il nostro gearless è **Made in Italy** perché è pensato e prodotto in Italia.

- **Tecnologia avanzata:** I nostri Gearless incorporano le ultime innovazioni del settore, garantendo massima efficienza, silenziosità e fluidità di movimento.
- **Cura del dettaglio:** Ogni componente viene sottoposto a rigorosi controlli qualitativi per assicurare un prodotto impeccabile e duraturo.
- **Made in Italy:** Valorizziamo il nostro know-how per offrire un prodotto con i più alti standard qualitativi garantendone anche l'assistenza.
- **Su misura per te:** I nostri Gearless sono personalizzabili per soddisfare le tue esigenze specifiche, garantendoti la soluzione perfetta per la tua applicazione.
- **Valorizzazione del territorio:** Contribuiamo allo sviluppo economico del nostro territorio e alla valorizzazione delle eccellenze italiane.

Passion at the service of those who choose our **expertise**

This is how we make gearless traction machine.

We meticulously craft each component to deliver a product that meets the most demanding technological requirements.

Our gearless are **Made in Italy**, designed and manufactured within our country.

- **Advanced technology:** Our gearless traction machines incorporate the latest innovations in the industry, ensuring maximum efficiency, smoothness, and quiet operation.
- **Attention to detail:** Each component undergoes rigorous quality controls to guarantee a flawless and long-lasting product.
- **Made in Italy:** We leverage our expertise to offer a product that adheres to the highest quality standards, also providing comprehensive support.
- **Tailored to your needs:** Our gearless can be customized to meet your specific requirements, ensuring the perfect solution for your application.
- **Enhancing the region:** We contribute to the economic development of our region and the promotion of Italian excellence.

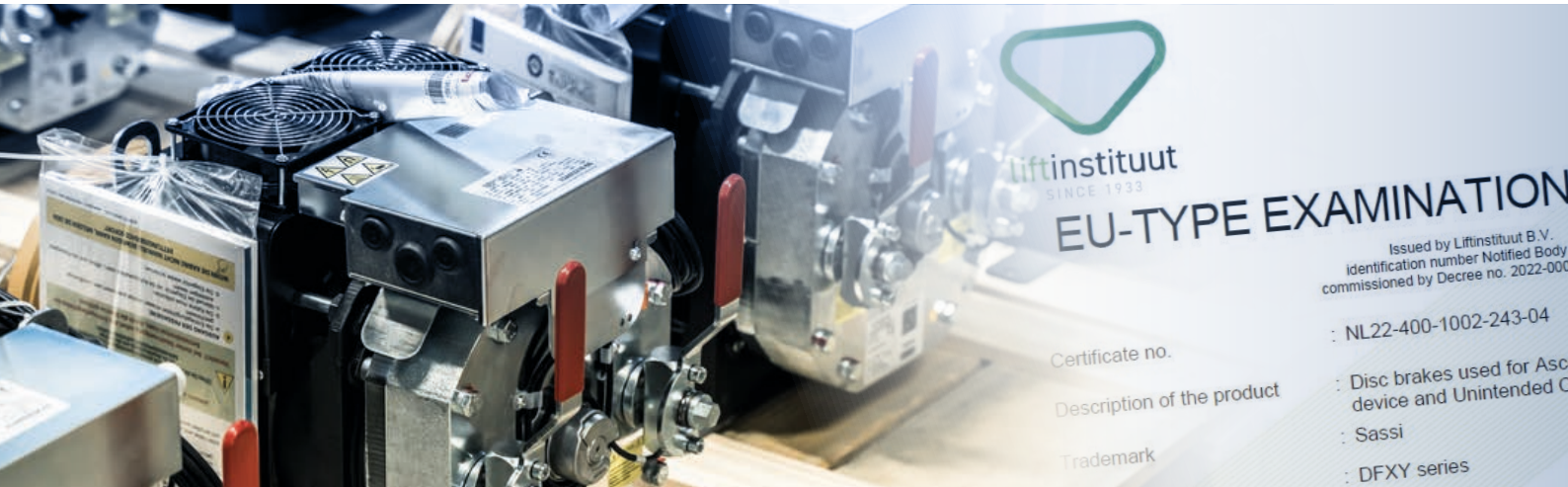

Freni brevettati e certificati per i nostri gearless

I freni DF, DG e DQ, frutto della nostra progettazione e produzione, sono i componenti chiave che garantiscono sicurezza e prestazioni elevate ai nostri gearless.

Un approccio costruttivo unico

Ogni componente e ogni dettaglio dei nostri prodotti sono frutto di un'attenta progettazione, uniti da un unico denominatore comune: la ricerca dell'eccellenza. I freni DF, DG e DQ rappresentano l'esempio tangibile di questa filosofia costruttiva, offrendo il massimo in termini di sicurezza e prestazioni.

Patented and certified brakes for our gearless

The DF, DG, and DQ brakes, the result of our in-house design and manufacturing, are the key components that ensure safety and high performance for our gearless.

A unique design approach

Every component and every detail of our products is the result of meticulous design, united by a single common denominator: the pursuit of excellence. The DF, DG, and DQ brakes epitomize this design philosophy, offering the pinnacle of safety and performance.



G-200 T1 . TS

Con o senza ventole di raffreddamento
With or without cooling fans

G-200 TC

Con o senza ventole di raffreddamento
With or without cooling fans

G-200 T1 · TS · TC

Senza ventole di raffreddamento
Without cooling fans

Con ventole di raffreddamento
With cooling fans

Carico statico / Static load [kg]	2500									
Coppia / Rated torque [Nm]	190					230				
Peso / Weight [kg]	122 (senza puleggia / without sheave)					134 (senza puleggia / without sheave)				
Portata / Duty load [kg]	300	320	400	450	480	630	320	400	630	800
Tiro / Roping	1/1	2/1	2/1	2/1	2/1	2/1	1/1	2/1		
Gamma velocità cabina Range of cabin speed [m/s]	0,63 ÷ 1,60					0,63 ÷ 1,00	0,63 ÷ 1,60			0,63 ÷ 1,00
Gamma Ø pulegge Range sheave Ø [mm]	120 140 160	120 → 240		120 → 210		120 140 160	160 210	160 210	160	
Max combinazione funi Max ropes combination [mm]	n°8 Ø 6 - 6,5 - 6,7									
Freno / Brake	DF11									
Poli / Poles	16									

G-200 T Senza ventole di raffreddamento / Without cooling fans

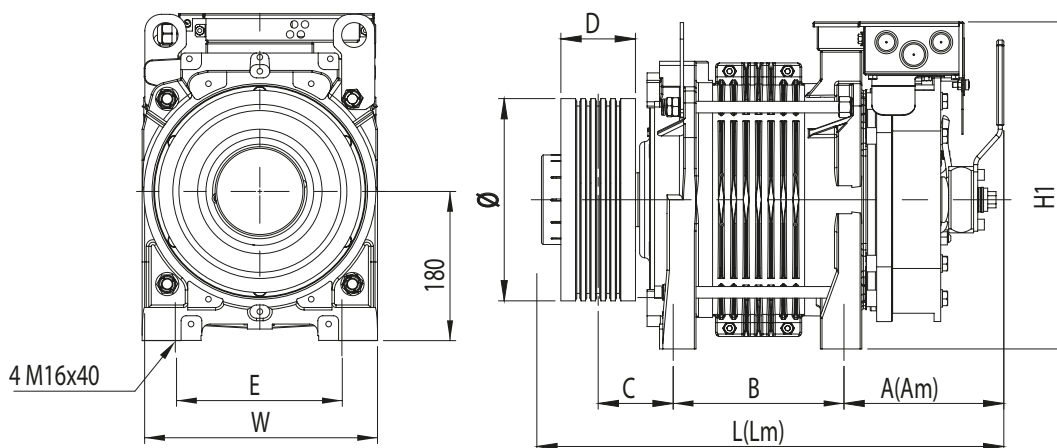

Dimensioni / Dimensions [mm]

A	L	Am*	Lm*	B	C	E	W	H1	D	Ø
147	512	192	557	206	90.5	200	284	395	90	120 - 140 - 160 - 210 - 240
	520		565		105.5				120	120 - 140 - 160
	520		565		95.5				120	210 - 240 - 320

* Quote con manovra apertura a mano. / Dimensions with lever for hand release.

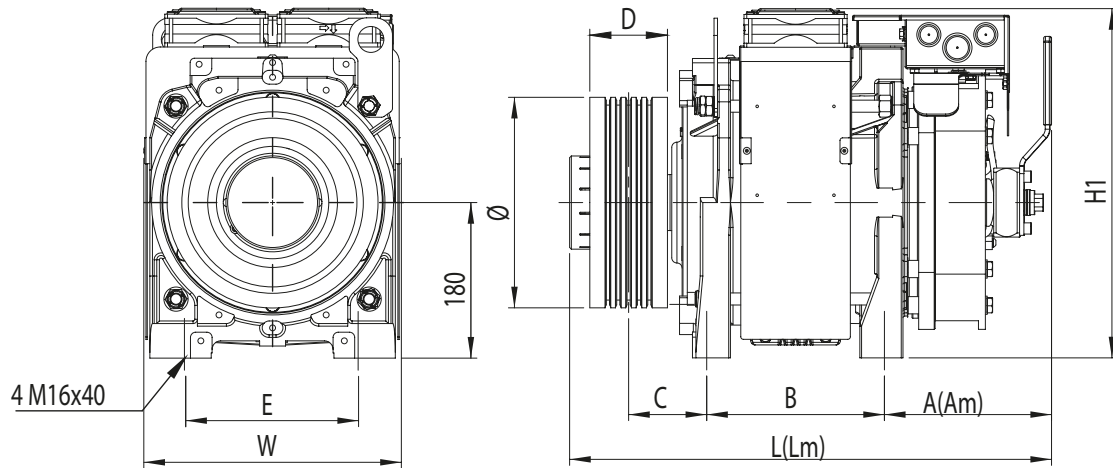

Dimensioni / Dimensions [mm]

A	L	Am*	Lm*	B	C	E	W	H1	D	Ø
147	512	192	557	206	90.5	200	296	405	90	120 - 140 - 160 - 210 - 240
	520		105.5		120				120 - 140 - 160	
	520		95.5		120				210 - 240 - 320	

* Quote con manovra apertura a mano. / Dimensions with lever for hand release.

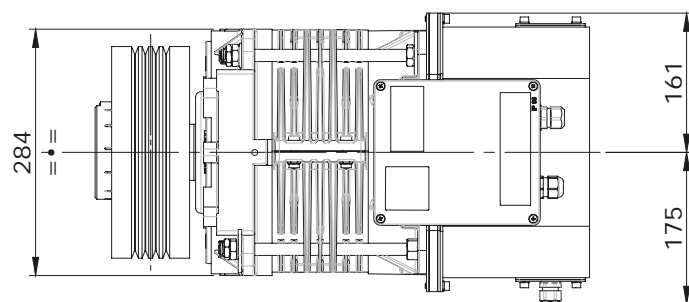
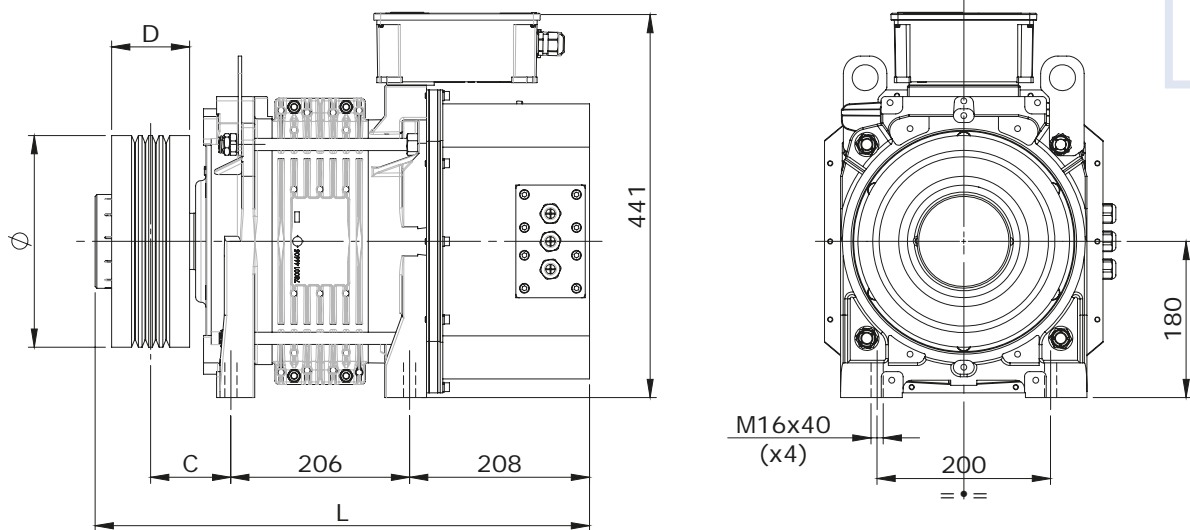

Dimensioni / Dimensions [mm]

L	C	D	Ø
572	90.5	90	120 - 140 - 160 - 210 - 240
580	105.5	120	120 - 140 - 160
580	95.5	120	210 - 240 - 320

G-200 TC Senza ventole di raffreddamento / Without cooling fans

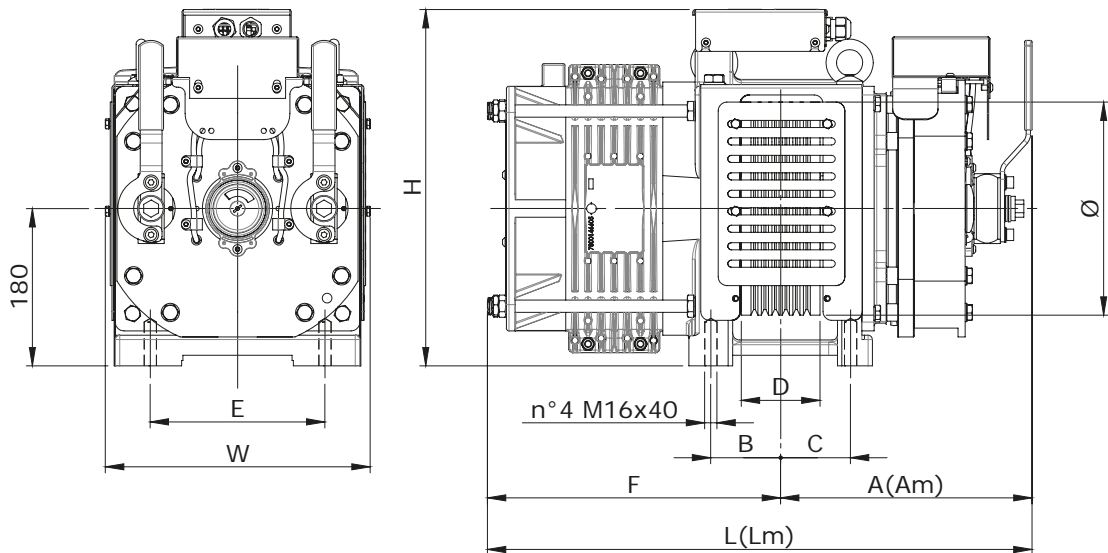

Encoder montato sul lato freno
Encoder mounted on the brake side

Unica direzione per l'uscita delle funi
Single direction rope exit

Dimensioni / Dimensions [mm]

A	L	Am*	Lm*	B	C	E	F	W	H	D	Ø
245	582	290	632	80	80	200	342	305	410	90	120 - 140 - 160 - 210 - 240
				87.5	72.5					105	120 - 140 - 160

* Quote con manovra apertura a mano. / Dimensions with lever for hand release.

G-200 TC Con ventole di raffreddamento / Without cooling fans

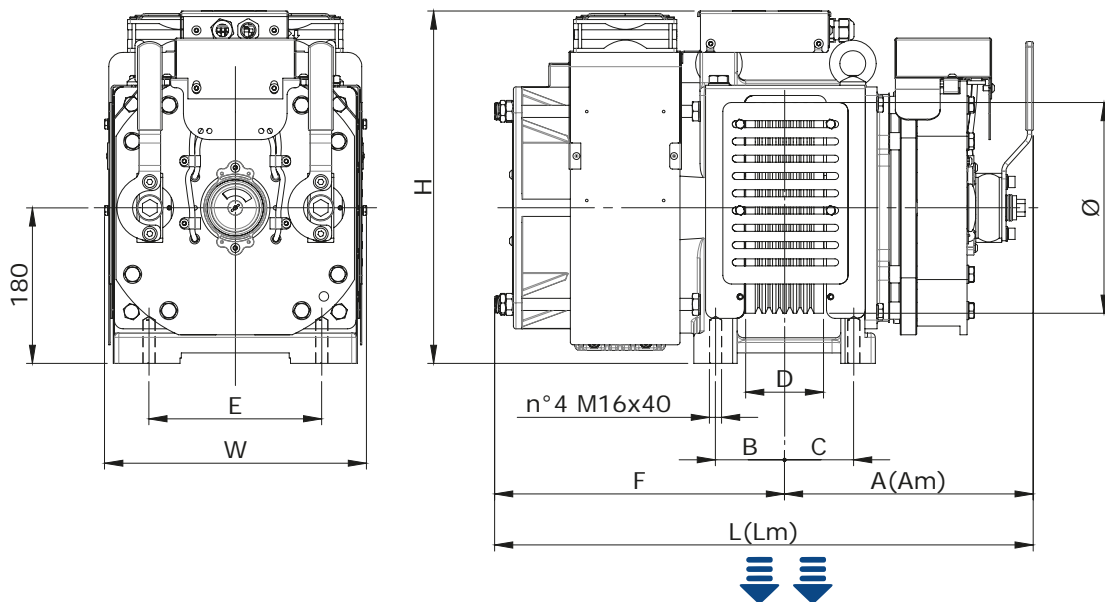

Encoder montato sul lato freno
Encoder mounted on the brake side

Unica direzione per l'uscita delle funi
Single direction rope exit

Dimensioni / Dimensions [mm]

A	L	Am*	Lm*	B	C	E	F	W	H	D	Ø
245	582	290	632	80	80	200	342	305	410	90	120 - 140 - 160 - 210 - 240
				87.5	72.5					105	120 - 140 - 160

* Quote con manovra apertura a mano. / Dimensions with lever for hand release.

**G-200 T1 · TC**

Tiro	Peso funi max	Portata	Velocità cabina	Ø Puleggia	Poli	Velocità	Frequenza	Efficienza vano	Coppia	Potenza in uscita
Roping	Max Ropes Weight	Duty Load	Cabin Speed	Sheave Diameter	Poles	Speed	Frequency	Shaft Efficiency	Torque	Power Output
	[kg]	[kg]	[m/s]	[mm]		[rpm]	[Hz]		[Nm]	[kW]
1	30	180	0,63	120	16	100,3	13,37	0,85	83	0,9
1	30	180	0,63	140	16	85,9	11,46	0,85	97	0,9
1	30	180	0,63	160	16	75,2	10,03	0,85	111	0,9
1	30	180	0,63	210	16	57,3	7,64	0,85	145	0,9
1	30	180	0,63	240	16	50,1	6,68	0,85	166	0,9
1	30	180	0,8	120	16	127,3	16,98	0,85	83	1,1
1	30	180	0,8	140	16	109,1	14,55	0,85	97	1,1
1	30	180	0,8	160	16	95,5	12,73	0,85	111	1,1
1	30	180	0,8	210	16	72,8	9,70	0,85	145	1,1
1	30	180	0,8	240	16	63,7	8,49	0,85	166	1,1
1	30	180	1	120	16	159,2	21,22	0,85	83	1,4
1	30	180	1	140	16	136,4	18,19	0,85	97	1,4
1	30	180	1	160	16	119,4	15,92	0,85	111	1,4
1	30	180	1	210	16	90,9	12,13	0,85	145	1,4
1	30	180	1	240	16	79,6	10,61	0,85	166	1,4
1	30	180	1,6	120	16	254,6	33,95	0,85	83	2,2
1	30	180	1,6	140	16	218,3	29,10	0,85	97	2,2
1	30	180	1,6	160	16	191,0	25,46	0,85	111	2,2
1	30	180	1,6	210	16	145,5	19,40	0,85	145	2,2
1	30	180	1,6	240	16	127,3	16,98	0,85	166	2,2
1	30	225	0,63	120	16	100,3	13,37	0,85	99	1,0
1	30	225	0,63	140	16	85,9	11,46	0,85	115	1,0
1	30	225	0,63	160	16	75,2	10,03	0,85	132	1,0
1	30	225	0,63	210	16	57,3	7,64	0,85	173	1,0
1	30	225	0,8	120	16	127,3	16,98	0,85	99	1,3
1	30	225	0,8	140	16	109,1	14,55	0,85	115	1,3
1	30	225	0,8	160	16	95,5	12,73	0,85	132	1,3
1	30	225	0,8	210	16	72,8	9,70	0,85	173	1,3
1	30	225	1	120	16	159,2	21,22	0,85	99	1,6
1	30	225	1	140	16	136,4	18,19	0,85	115	1,6
1	30	225	1	160	16	119,4	15,92	0,85	132	1,6
1	30	225	1	210	16	90,9	12,13	0,85	173	1,6
1	30	225	1,6	120	16	254,6	33,95	0,85	99	2,6
1	30	225	1,6	140	16	218,3	29,10	0,85	115	2,6
1	30	225	1,6	160	16	191,0	25,46	0,85	132	2,6
1	30	225	1,6	210	16	145,5	19,40	0,85	173	2,6
1	30	300	0,63	120	16	100,3	13,37	0,85	125	1,3
1	30	300	0,63	140	16	85,9	11,46	0,85	145	1,3
1	30	300	0,63	160	16	75,2	10,03	0,85	166	1,3
1	30	300	0,8	120	16	127,3	16,98	0,85	125	1,7
1	30	300	0,8	140	16	109,1	14,55	0,85	145	1,7
1	30	300	0,8	160	16	95,5	12,73	0,85	166	1,7
1	30	300	1	120	16	159,2	21,22	0,85	125	2,1
1	30	300	1	140	16	136,4	18,19	0,85	145	2,1
1	30	300	1	160	16	119,4	15,92	0,85	166	2,1
1	30	300	1,6	120	16	254,6	33,95	0,85	125	3,3
1	30	300	1,6	140	16	218,3	29,10	0,85	145	3,3
1	30	300	1,6	160	16	191,0	25,46	0,85	166	3,3



Tiro	Peso funi max	Portata	Velocità cabina	Ø Puleggia	Poli	Velocità	Frequenza	Efficienza vano	Coppia	Potenza in uscita
Roping	Max Ropes Weight	Duty Load	Cabin Speed	Sheave Diameter	Poles	Speed	Frequency	Shaft Efficiency	Torque	Power Output
	[kg]	[kg]	[m/s]	[mm]		[rpm]	[Hz]		[Nm]	[kW]
1	30	375	0,63	120	16	100,3	13,37	0,85	151	1,6
1	30	375	0,63	140	16	85,9	11,46	0,85	176	1,6
1	30	375	0,8	120	16	127,3	16,98	0,85	151	2,0
1	30	375	0,8	140	16	109,1	14,55	0,85	176	2,0
1	30	375	1	120	16	159,2	21,22	0,85	151	2,5
1	30	375	1	140	16	136,4	18,19	0,85	176	2,5
1	30	375	1,6	120	16	254,6	33,95	0,85	151	4,0
1	30	375	1,6	140	16	218,3	29,10	0,85	176	4,0
1	30	400	0,63	120	16	100,3	13,37	0,85	159	1,7
1	30	400	0,63	140	16	85,9	11,46	0,85	186	1,7
1	30	400	0,8	120	16	127,3	16,98	0,85	159	2,1
1	30	400	0,8	140	16	109,1	14,55	0,85	186	2,1
1	30	400	1	120	16	159,2	21,22	0,85	159	2,7
1	30	400	1	140	16	136,4	18,19	0,85	186	2,7
1	30	400	1,6	120	16	254,6	33,95	0,85	159	4,2
1	30	400	1,6	140	16	218,3	29,10	0,85	186	4,2
1	30	450	0,63	120	16	100,3	13,37	0,85	177	1,9
1	30	450	0,8	120	16	127,3	16,98	0,85	177	2,4
1	30	450	1	120	16	159,2	21,22	0,85	177	2,9
1	30	450	1,6	120	16	254,6	33,95	0,85	177	4,7
1	30	480	0,63	120	16	100,3	13,37	0,85	187	2,0
1	30	480	0,8	120	16	127,3	16,98	0,85	187	2,5
1	30	480	1	120	16	159,2	21,22	0,85	187	3,1
1	30	480	1,6	120	16	254,6	33,95	0,85	187	5,0
2	30	400	0,63	120	16	200,5	26,74	0,85	90	1,9
2	30	400	0,63	140	16	171,9	22,92	0,85	105	1,9
2	30	400	0,63	160	16	150,4	20,05	0,85	120	1,9
2	30	400	0,63	210	16	114,6	15,28	0,85	158	1,9
2	30	400	0,63	240	16	100,3	13,37	0,85	180	1,9
2	30	400	0,8	120	16	254,6	33,95	0,85	90	2,4
2	30	400	0,8	140	16	218,3	29,10	0,85	105	2,4
2	30	400	0,8	160	16	191,0	25,46	0,85	120	2,4
2	30	400	0,8	210	16	145,5	19,40	0,85	158	2,4
2	30	400	0,8	240	16	127,3	16,98	0,85	180	2,4
2	30	400	1	120	16	318,3	42,44	0,85	90	3,0
2	30	400	1	140	16	272,8	36,38	0,85	105	3,0
2	30	400	1	160	16	238,7	31,83	0,85	120	3,0
2	30	400	1	210	16	181,9	24,25	0,85	158	3,0
2	30	400	1	240	16	159,2	21,22	0,85	180	3,0
2	30	400	1,6	210	16	291,0	38,80	0,85	158	4,8
2	30	400	1,6	240	16	254,6	33,95	0,85	180	4,8
2	30	450	0,63	120	16	200,5	26,74	0,85	99	2,1
2	30	450	0,63	140	16	171,9	22,92	0,85	115	2,1
2	30	450	0,63	160	16	150,4	20,05	0,85	132	2,1
2	30	450	0,63	210	16	114,6	15,28	0,85	173	2,1
2	30	450	0,8	120	16	254,6	33,95	0,85	99	2,6
2	30	450	0,8	140	16	218,3	29,10	0,85	115	2,6
2	30	450	0,8	160	16	191,0	25,46	0,85	132	2,6
2	30	450	0,8	210	16	145,5	19,40	0,85	173	2,6
2	30	450	1	120	16	318,3	42,44	0,85	99	3,3
2	30	450	1	140	16	272,8	36,38	0,85	115	3,3
2	30	450	1	160	16	238,7	31,83	0,85	132	3,3

Tiro	Peso funi max	Portata	Velocità cabina	Ø Puleggia	Poli	Velocità	Frequenza	Efficienza vano	Coppia	Potenza in uscita
Roping	Max Ropes Weight	Duty Load	Cabin Speed	Sheave Diameter	Poles	Speed	Frequency	Shaft Efficiency	Torque	Power Output
	[kg]	[kg]	[m/s]	[mm]		[rpm]	[Hz]		[Nm]	[kW]
2	30	450	1	210	16	181,9	24,25	0,85	173	3,3
2	30	450	1,6	210	16	291,0	38,80	0,85	173	5,3
2	30	480	0,63	120	16	200,5	26,74	0,85	104	2,2
2	30	480	0,63	140	16	171,9	22,92	0,85	121	2,2
2	30	480	0,63	160	16	150,4	20,05	0,85	138	2,2
2	30	480	0,63	210	16	114,6	15,28	0,85	182	2,2
2	30	480	0,8	120	16	254,6	33,95	0,85	104	2,8
2	30	480	0,8	140	16	218,3	29,10	0,85	121	2,8
2	30	480	0,8	160	16	191,0	25,46	0,85	138	2,8
2	30	480	0,8	210	16	145,5	19,40	0,85	182	2,8
2	30	480	1	120	16	318,3	42,44	0,85	104	3,5
2	30	480	1	140	16	272,8	36,38	0,85	121	3,5
2	30	480	1	160	16	238,7	31,83	0,85	138	3,5
2	30	480	1	210	16	181,9	24,25	0,85	182	3,5
2	30	480	1,6	210	16	291,0	38,80	0,85	182	5,5
2	30	630	0,63	120	16	200,5	26,74	0,85	130	2,7
2	30	630	0,63	140	16	171,9	22,92	0,85	151	2,7
2	30	630	0,63	160	16	150,4	20,05	0,85	173	2,7
2	30	630	0,8	120	16	254,6	33,95	0,85	130	3,5
2	30	630	0,8	140	16	218,3	29,10	0,85	151	3,5
2	30	630	0,8	160	16	191,0	25,46	0,85	173	3,5
2	30	630	1	120	16	318,3	42,44	0,85	130	4,3
2	30	630	1	140	16	272,8	36,38	0,85	151	4,3
2	30	630	1	160	16	238,7	31,83	0,85	173	4,3
2	30	750	0,63	120	16	200,5	26,74	0,85	151	3,2
2	30	750	0,63	140	16	171,9	22,92	0,85	176	3,2
2	30	750	0,8	120	16	254,6	33,95	0,85	151	4,0
2	30	750	0,8	140	16	218,3	29,10	0,85	176	4,0
2	30	750	1	120	16	318,3	42,44	0,85	151	5,0
2	30	750	1	140	16	272,8	36,38	0,85	176	5,0
2	30	800	0,63	120	16	200,5	26,74	0,85	159	3,3
2	30	800	0,63	140	16	171,9	22,92	0,85	186	3,3
2	30	800	0,8	120	16	254,6	33,95	0,85	159	4,2
2	30	800	0,8	140	16	218,3	29,10	0,85	186	4,2
2	30	800	1	120	16	318,3	42,44	0,85	159	5,3
2	30	800	1	140	16	272,8	36,38	0,85	186	5,3

Note 1

Note 2

Note 3

max 190

G-200 T1 · TC | Note / Notes

Brake Type: DF11 - 205 V DC Standard. Other voltages on request. DFXY certified brake against Overspeed in upward direction and as UCM (EN 81-20:2020, EN 81-50:2020) with reference to Lift Directive 2014/33/EU.

Encoder Type: Absolute encoder with EnDat Interface or Incremental sin/cos, both with 2048 ppr.

Duty-cycle: Max 240 sts/h - 40% ED without fans.
Max 240 sts/h - 50% ED with fans activated by thermocontacts inside motor.

Traction sheave:

G-200 T1: Traction sheave width 90 mm. Available width 120 mm; traction sheave Ø320 only with width 120 mm.
G-200 TC: Traction sheave width 90 mm. Available width 105 mm for Ø120, Ø140, Ø160 mm.
Sheave Ø320 mm not available.

Note 1:

For higher ropes weight, please consult sales/technical services of Alberto Sassi SpA.

Note 2:

Details on ropes/grooves provided upon lift data. Suitable for steel core ropes or also for plastic coated ropes.

Note 3:

Shaft efficiency includes divertor pulleys efficiency by considering: 3 divertors for roping 2:1. Values are supposed.

G-200 TS · TC

Tiro	Peso funi max	Portata	Velocità cabina	Ø Puleggia	Poli	Velocità	Frequenza	Efficienza vano	Coppia	Potenza in uscita
Roping	Max Ropes Weight	Duty Load	Cabin Speed	Sheave Diameter	Poles	Speed	Frequency	Shaft Efficiency	Torque	Power Output
	[kg]	[kg]	[m/s]	[mm]		[rpm]	[Hz]		[Nm]	[kW]
1	30	225	0,63	240	16	50,1	6,68	0,85	197	1,0
1	30	225	0,8	240	16	63,7	8,49	0,85	197	1,3
1	30	225	1	240	16	79,6	10,61	0,85	197	1,6
1	30	225	1,6	240	16	127,3	16,98	0,85	197	2,6
1	30	300	0,63	210	16	57,3	7,64	0,85	218	1,3
1	30	300	0,8	210	16	72,8	9,70	0,85	218	1,7
1	30	300	1	210	16	90,9	12,13	0,85	218	2,1
1	30	300	1,6	210	16	145,5	19,40	0,85	218	3,3
1	30	375	0,63	160	16	75,2	10,03	0,85	201	1,6
1	30	375	0,8	160	16	95,5	12,73	0,85	201	2,0
1	30	375	1	160	16	119,4	15,92	0,85	201	2,5
1	30	375	1,6	160	16	191,0	25,46	0,85	201	4,0
1	30	400	0,63	160	16	75,2	10,03	0,85	212	1,7
1	30	400	0,8	160	16	95,5	12,73	0,85	212	2,1
1	30	400	1	160	16	119,4	15,92	0,85	212	2,7
1	30	400	1,6	160	16	191,0	25,46	0,85	212	4,2
1	30	450	0,63	140	16	85,9	11,46	0,85	206	1,9
1	30	450	0,8	140	16	109,1	14,55	0,85	206	2,4
1	30	450	1	140	16	136,4	18,19	0,85	206	2,9
1	30	450	1,6	140	16	218,3	29,10	0,85	206	4,7
1	30	480	0,63	140	16	85,9	11,46	0,85	218	2,0
1	30	480	0,8	140	16	109,1	14,55	0,85	218	2,5
1	30	480	1	140	16	136,4	18,19	0,85	218	3,1
1	30	480	1,6	140	16	218,3	29,10	0,85	218	5,0
2	30	375	0,63	120	16	200,5	26,74	0,85	86	1,8
2	30	375	0,63	140	16	171,9	22,92	0,85	100	1,8
2	30	375	0,63	160	16	150,4	20,05	0,85	114	1,8
2	30	375	0,63	210	16	114,6	15,28	0,85	150	1,8
2	30	375	0,63	240	16	100,3	13,37	0,85	171	1,8
2	30	375	0,63	320 *	16	75,2	10,03	0,85	229	1,8
2	30	375	0,8	120	16	254,6	33,95	0,85	86	2,3
2	30	375	0,8	140	16	218,3	29,10	0,85	100	2,3
2	30	375	0,8	160	16	191,0	25,46	0,85	114	2,3
2	30	375	0,8	210	16	145,5	19,40	0,85	150	2,3
2	30	375	0,8	240	16	127,3	16,98	0,85	171	2,3
2	30	375	0,8	320 *	16	95,5	12,73	0,85	229	2,3
2	30	375	1	120	16	318,3	42,44	0,85	86	2,9
2	30	375	1	140	16	272,8	36,38	0,85	100	2,9
2	30	375	1	160	16	238,7	31,83	0,85	114	2,9
2	30	375	1	210	16	181,9	24,25	0,85	150	2,9
2	30	375	1	240	16	159,2	21,22	0,85	171	2,9
2	30	375	1	320 *	16	119,4	15,92	0,85	229	2,9
2	30	375	1,6	210	16	291,0	38,80	0,85	150	4,6
2	30	375	1,6	240	16	254,6	33,95	0,85	171	4,6
2	30	375	1,6	320 *	16	191,0	25,46	0,85	229	4,6
2	30	450	0,63	240	16	100,3	13,37	0,85	197	2,1
2	30	450	0,8	240	16	127,3	16,98	0,85	197	2,6
2	30	450	1	240	16	159,2	21,22	0,85	197	3,3
2	30	450	1,6	240	16	254,6	33,95	0,85	197	5,3
2	30	480	0,63	240	16	100,3	13,37	0,85	208	2,2

Tiro	Peso funi max	Portata	Velocità cabina	Ø Puleggia	Poli	Velocità	Frequenza	Efficienza vano	Coppia	Potenza in uscita
Roping	Max Ropes Weight	Duty Load	Cabin Speed	Sheave Diameter	Poles	Speed	Frequency	Shaft Efficiency	Torque	Power Output
	[kg]	[kg]	[m/s]	[mm]		[rpm]	[Hz]		[Nm]	[kW]
2	30	480	0,8	240	16	127,3	16,98	0,85	208	2,8
2	30	480	1	240	16	159,2	21,22	0,85	208	3,5
2	30	480	1,6	240	16	254,6	33,95	0,85	208	5,5
2	30	630	0,63	210	16	114,6	15,28	0,85	227	2,7
2	30	630	0,8	210	16	145,5	19,40	0,85	227	3,5
2	30	630	1	210	16	181,9	24,25	0,85	227	4,3
2	30	630	1,6	210	16	291,0	38,80	0,85	227	6,9
2	30	750	0,63	160	16	150,4	20,05	0,85	201	3,2
2	30	750	0,8	160	16	191,0	25,46	0,85	201	4,0
2	30	750	1	160	16	238,7	31,83	0,85	201	5,0
2	30	800	0,63	160	16	150,4	20,05	0,85	212	3,3
2	30	800	0,8	160	16	191,0	25,46	0,85	212	4,2
2	30	800	1	160	16	238,7	31,83	0,85	212	5,3

Note 1

Note 2

Note 3

max 230

G-200 TS · TC | Note / Notes

Brake Type: DF11 - 205 V DC Standard. Other voltages on request. DFX certified brake against Overspeed in upward direction and as UCM (EN 81-20:2020, EN 81-50:2020) with reference to Lift Directive 2014/33/EU.

Encoder Type: Absolute encoder with EnDat Interface or Incremental sin/cos, both with 2048 ppr.

Duty-cycle: Max 180 sts/h - 40% ED with fans activated by thermocontacts inside motor.

Traction sheave: G-200 TS: Traction sheave width 90 mm. Available width 120 mm; traction sheave Ø320 only with width 120 mm. G-200 TC: Traction sheave width 90 mm. Available width 105 mm for Ø120, Ø140, Ø160 mm. Sheave Ø320 mm not available.

* Sheave diameter available only for G-200 TS.

Note 1: For higher ropes weight, please consult sales/technical services of Alberto Sassi SpA.

Note 2: Details on ropes/grooves provided upon lift data. Suitable for steel core ropes or also for plastic coated ropes.

Note 3: Shaft efficiency includes divertor pulleys efficiency by considering: 3 divertors for roping 2:1. Values are supposed.

G-200

Combinazione funi / Ropes combination

Tiro / Roping 1/1 · Corsa / Travel 30 mt						
Portata Duty load [kg]	Velocità Speed [m/s]	Puleggia Sheave [mm]	Combinazione funi Ropes combination	N° funi max Max ropes nr.	Peso cabina Cabin weight [kg]	
225	0,63 - 1,60	160 - 210 - 240	4÷6 x ø 6/6,5	8 x ø 6/6,5	300	450
320	0,63 - 1,60	160 - 210	5÷7 x ø 6/6,5	8 x ø 6/6,5	350	550
375	0,63 - 1,60	160	5÷7 x ø 6/6,5	8 x ø 6/6,5	400	500
400	0,63 - 1,60	160	5÷7 x ø 6/6,5	8 x ø 6/6,5	450	500

Tiro / Roping 2/1 · Corsa / Travel 30 mt						
Portata Duty load [kg]	Velocità Speed [m/s]	Puleggia Sheave [mm]	Combinazione funi Ropes combination	N° funi max Max ropes nr.	Peso cabina Cabin weight [kg]	
225	0,63 - 1,60	160 - 210 - 240	3÷4 ø 6/6,5	8 x ø 6/6,5	400	500
320	0,63 - 1,60	160 - 210 - 240	4÷5 ø 6/6,5	8 x ø 6/6,5	500	600
375	0,63 - 1,60	160 - 210 - 240	4÷5 ø 6/6,5	8 x ø 6/6,5	500	600
450	0,63 - 1,60	160 - 210 - 240	5÷6 x ø 6/6,5	8 x ø 6/6,5	700	900
480	0,63 - 1,60	160 - 210 - 240	5÷6 x ø 6/6,5	8 x ø 6/6,5	700	900
525	0,63 - 1,60	160 - 210 - 240	5÷7 x ø 6/6,5	8 x ø 6/6,5	600	1000
630	0,63 - 1,60	160 - 210	5÷7 x ø 6/6,5	8 x ø 6/6,5	700	1000
800	0,63 - 1,60	160	6÷8 x ø 6/6,5	8 x ø 6/6,5	800	1000

Altre combinazioni a richiesta. / Additional combination on request.

GEARLESS
| G-200 |
ALBERTO SASSI
13

**G-300 T0 · TS****G-300 TC****G-300 TC**Con ventole di raffreddamento
Without cooling fansSenza ventole di raffreddamento
Without cooling fans

G-300 T0 · TS · TC	Senza ventole di raffreddamento Without cooling fans					Con ventole di raffreddamento Without cooling fans				
Carico statico Static load [kg]	2750 (2500*)					2750 (2500*)				
Coppia / Rated torque [Nm]	270					320				
Peso / Weight [kg]	162 (senza puleggia / without sheave)					165 (senza puleggia / without sheave)				
Portata / Duty load [kg]	225	320	525	225 - 320	450	630	450	525	800	
Tiro / Roping	1/1	1/1	1/1	2/1	2/1	2/1	1/1	2/1	2/1	
Gamma velocità cabina Range of cabin speed [m/s]	0.63 ÷ 1.60									
Gamma Ø pulegge Range sheave Ø [mm] G-300 T0 · TS	120 → 320	120 → 240	120 → 160	120 → 240	120 → 320	120 → 240	210	320	210 - 240	
Gamma Ø pulegge Range sheave Ø [mm] G-300 TC	120 → 240	120 → 240	120 → 160	120 → 240	120 → 240	120 → 240	210	240	210 - 240	
Max combinazione funi Max roping combination [mm]	n°10 Ø 6/6.5/6.7	n°10 Ø 6/6.5/6.7	n°6 Ø 6/8,1	n°10 Ø 6/6.5/6.7	n°10 Ø 6/6.5/6.7	n°10 Ø 6/6.5/6.7	n°10 Ø 6/6.5/6.7	n°10 Ø 6/6.5/6.7	n°10 Ø 6/6.5/6.7	
	n°8 Ø 8			n°8 Ø 8	n°8 Ø 8			n°8 Ø 8	n°10 Ø 6/6.5/6.7	
Larghezza pulegge Sheave width [mm]	G-300 T0 · TS: 90 - 120 - 150 G-300 TC: 90 - 105									
Freno / Brake	G-300 T0 · TS: DF01 G-300 TC: DFA1									
Poli / Poles	16									

* **G-300 T0 · TS:** Carico statico con larghezza puleggia 150 mm. / Static load with pulley width 150 mm.

A richiesta disponibili: leve apertura manuale freno. / Available on request: levers for hand release.

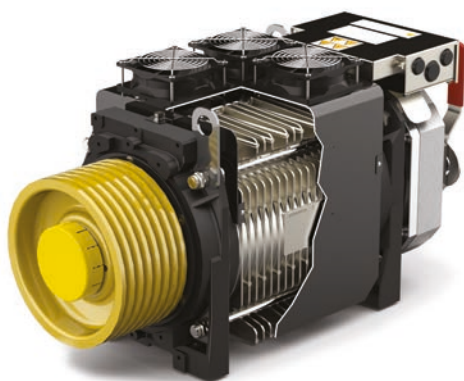

**G-300 T1**Con o senza ventole di raffreddamento
*With or without cooling fans***G-300 T2**Con ventole di raffreddamento
*With cooling fans***G-300 T1** Con o senza ventole di raffreddamento / *With or without cooling fans*

Carico statico <i>Static load [kg]</i>	2750 (2500*)							
Coppia / <i>Rated torque [Nm]</i>	430							
Peso / <i>Weight [kg]</i>	196 (senza ventole di raffreddamento/ <i>without cooling fans</i> - senza puleggia / <i>without sheave</i>) 200 (con ventole di raffreddamento/ <i>with cooling fans</i> - senza puleggia / <i>without sheave</i>)							
Portata / <i>Duty load [kg]</i>	225 - 320	400	525	630	800	450	630-800	1000
Tiro / <i>Roping</i>	1/1	1/1	1/1	1/1	1/1	2/1	2/1	2/1
Gamma velocità cabina <i>Range of cabin speed [m/s]</i>	0.63 ÷ 1.60							
Gamma Ø pulegge <i>Range sheave Ø [mm]</i>	120 → 320	360 → 400	120 → 240	120 → 210	120 → 160	360 → 400	120 → 320	120 → 240
Max combinazione funi <i>Max roping combination [mm]</i>	n°10 Ø 6/6,5/6,7	n°8 Ø 8	n°10 Ø 6/6,5/6,7	n°10 Ø 6/6,5/6,7	n°6 Ø 6/8,1	n°8 Ø 9/10	n°10 Ø 6/6,5/6,7	n°10 Ø 6
	n°8 Ø 8						n°8 Ø 8	
Larghezza pulegge <i>Sheave width [mm]</i>	90 - 120 - 150							
Freno / <i>Brake</i>	DF01							
Poli / <i>Poles</i>	16							

G-300 T2 Con ventole di raffreddamento / *With cooling fans*

Carico statico <i>Static load [kg]</i>	2750 (2500*)				
Coppia / <i>Rated torque [Nm]</i>	520				
Peso / <i>Weight [kg]</i>	208 (senza puleggia / <i>without sheave</i>)				
Portata / <i>Duty load [kg]</i>	400	630	800	1000	1250
Tiro / <i>Roping</i>	1/1	1/1	2/1	2/1	
Gamma velocità cabina <i>Range of cabin speed [m/s]</i>	0.63 ÷ 1.60				
Gamma Ø pulegge <i>Range sheave Ø [mm]</i>	360 - 400	210 - 240	360	210 - 240 - 320	210 - 240
Max combinazione funi <i>Max roping combination [mm]</i>	n°8 Ø 9/10	n°10 Ø 6	n°8 Ø 9	n°10 Ø 6/6,5/6,7	n°10 Ø 6
		n°10 Ø 6,5/6,7		n°8 Ø 8	n°10 Ø 6/6,5
Larghezza pulegge <i>Sheave width [mm]</i>	90 - 120 - 150				
Freno / <i>Brake</i>	DF02				
Poli / <i>Poles</i>	16				

* Carico statico con larghezza puleggia 150 mm. / *Static load with pulley width 150 mm.*A richiesta disponibili: Leve apertura manuale freno. *Available on request: Levers for hand release. G-300 T2 without cooling fans service limited to 90sts/h - 20% ED.*

G-300 Senza ventole di raffreddamento / Without cooling fans

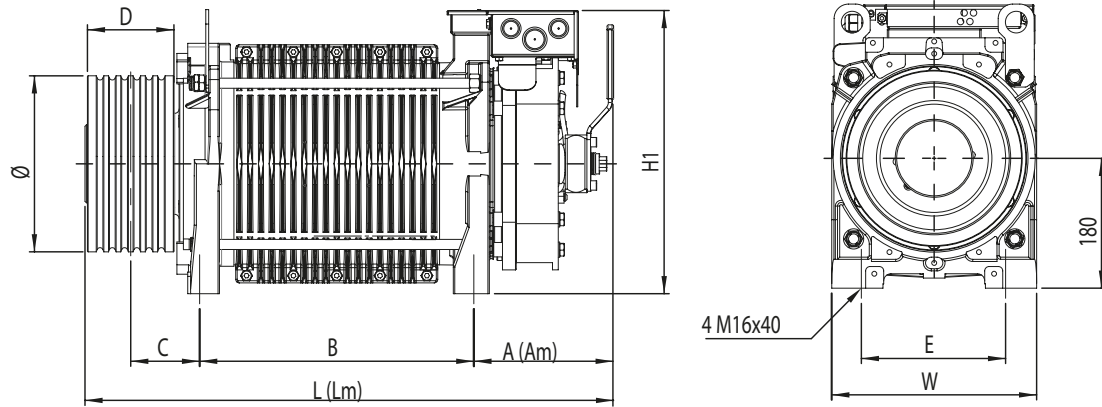

Dimensioni / Dimensions [mm]

Tipo / Type	A	L	Am*	Lm*	B	C	E	W	H1	D	Ø
G-300 T0	147	569	192	614	264	90.5	200	284	395	90	120 - 140 - 160 - 210 - 240
	147	577	192	622	264	105.5	200	284	395	120	120 - 140 - 160
	147	577	192	622	264	95.5	200	284	395	120	210 - 240 - 320
	147	605	192	650	264	110.5	200	284	395	150	240 - 320
G-300 T1	147	687	192	732	380	90.5	200	284	395	90	120 - 140 - 160 - 210 - 240
	147	695	192	740	380	105.5	200	284	395	120	120 - 140 - 160
	147	695	192	740	380	95.5	200	284	395	120	210 - 240 - 320 - 360 - 400
	147	720	192	765	380	110.5	200	284	395	150	240 - 320 - 360 - 400

* Quote con manovra apertura a mano. / Dimensions with lever for hand release.

G-300 Con ventole di raffreddamento / With cooling fans

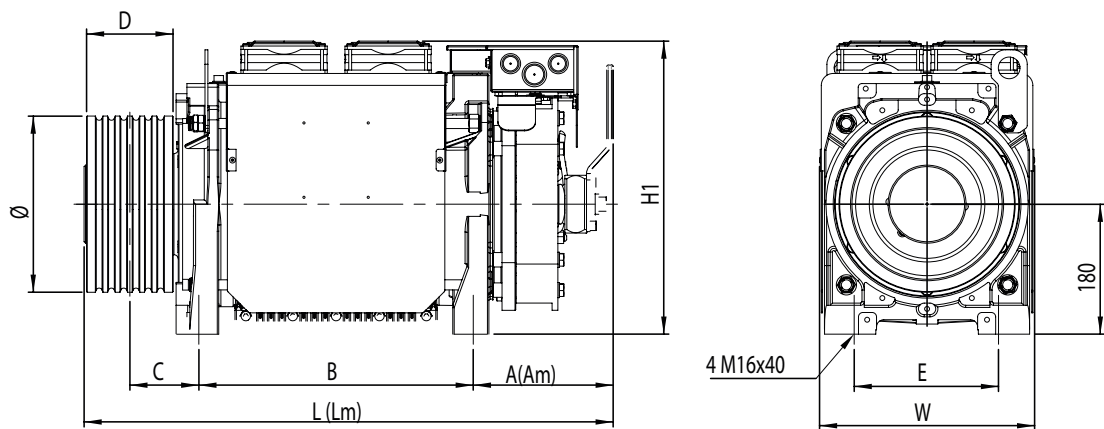

Dimensioni / Dimensions [mm]

Tipo / Type	A	L	Am*	Lm*	B	C	E	W	H1	D	Ø
G-300 T0 · TS	147	569	192	614	264	90.5	200	296	405	90	120 - 140 - 160 - 210 - 240
	147	577	192	622	264	105.5	200	296	405	120	120 - 140 - 160
	147	577	192	622	264	95.5	200	296	405	120	210 - 240 - 320
	147	605	192	650	264	110.5	200	296	405	150	240 - 320
G-300 T1	147	687	192	732	380	90.5	200	296	405	90	120 - 140 - 160 - 210 - 240
	147	695	192	740	380	105.5	200	296	405	120	120 - 140 - 160
	147	695	192	740	380	95.5	200	296	405	120	210 - 240 - 320 - 360 - 400
	147	720	192	765	380	110.5	200	296	405	150	240 - 320 - 360 - 400
G-300 T2	178	718	223	763	380	90.5	200	296	405	90	120 - 140 - 160 - 210 - 240
	178	726	223	771	380	105.5	200	296	405	120	120 - 140 - 160
	178	726	223	771	380	95.5	200	296	405	120	210 - 240 - 320 - 360 - 400
	178	751	223	796	380	110.5	200	296	405	150	240 - 320 - 360 - 400

* Quote con manovra apertura a mano. / Dimensions with lever for hand release.

G-300 T0 IP66* Senza ventole di raffreddamento / Without cooling fans

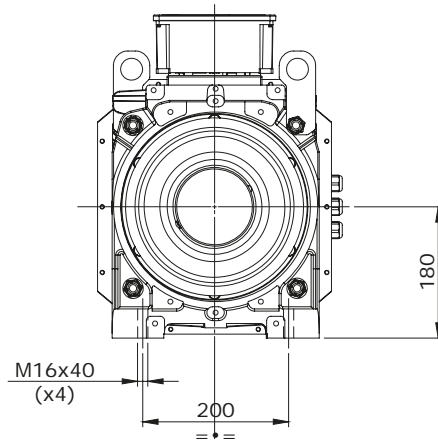
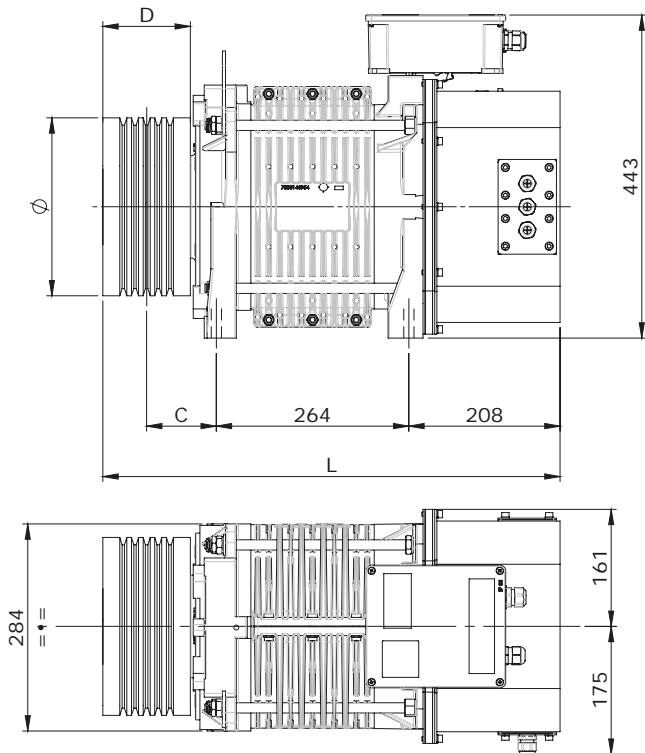

Dimensioni / Dimensions [mm]

L	C	D	Ø
629	90.5	90	120 - 140 - 160 - 210 - 240
637	105.5	120	120 - 140 - 160
637	95.5	120	210 - 240 - 320
665	110.5	150	240 - 320

* Configurazione solo senza ventilatore né leve del freno.
Configuration without neither fan nor brake levers.

G-300 T1 IP66* Senza ventole di raffreddamento / Without cooling fans

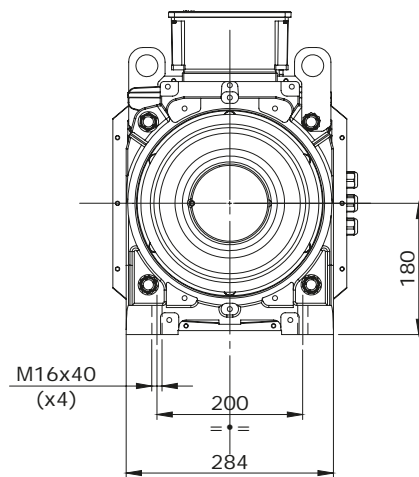
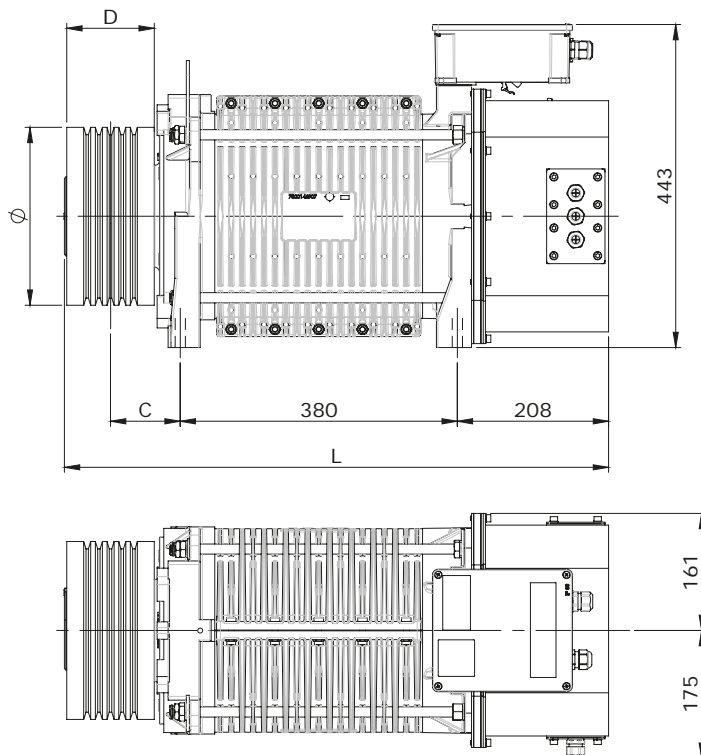

Dimensioni / Dimensions [mm]

L	C	D	Ø
747	90.5	90	120 - 140 - 160 - 210 - 240
755	105.5	120	120 - 140 - 160
755	95.5	120	210 - 240 - 320 - 360 - 400
780	110.5	150	240 - 320 - 360 - 400

* Configurazione solo senza ventilatore né leve del freno.
Configuration without neither fan nor brake levers.

G-300 T1* Con ventilatore speciale / With special cooling fan

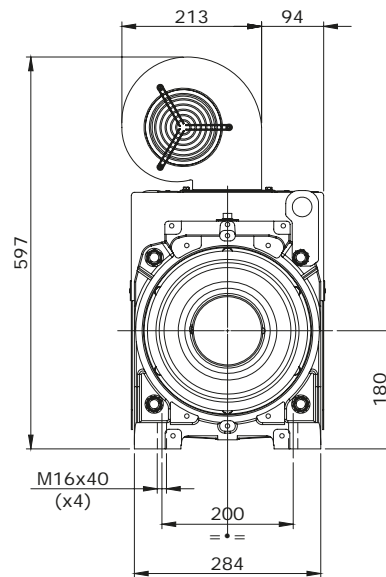
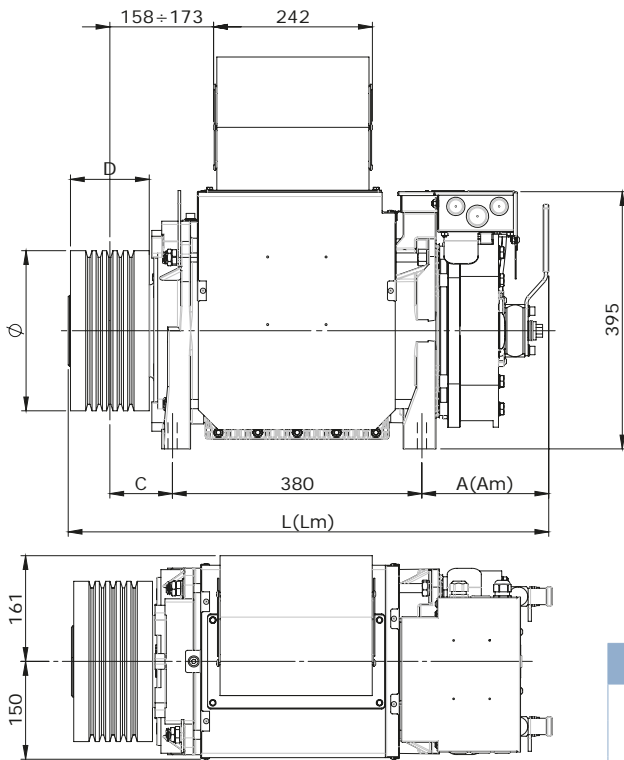

Dimensioni / Dimensions [mm]

A	L	Am**	Lm**	C	D	Ø
147	687	192	732	90.5	90	120 - 140 - 160 - 210 - 240
	695		740	105.5	120	120 - 140 - 160
	695		740	95.5	120	210 - 240 - 320 - 360 - 400
	720		765	110.5	150	240 - 320 - 360 - 400

* Per un maggiore ciclo di lavoro rispetto allo standard. Chiedere all'ufficio commerciale per maggiori informazioni.

For increased duty-cycle than the standard. Contact Sales dept. for further information.

** Quote con manovra apertura a mano. / Dimensions with lever for hand release.

G-300 T2* Con ventilatore speciale / With special cooling fan

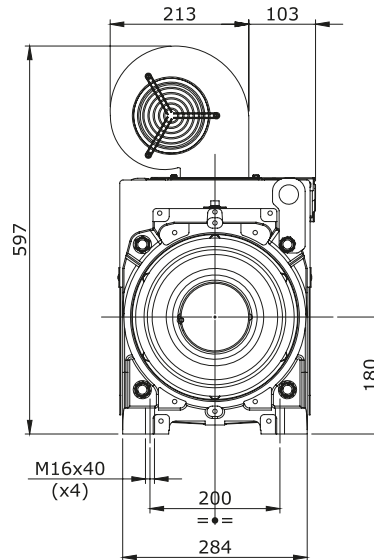
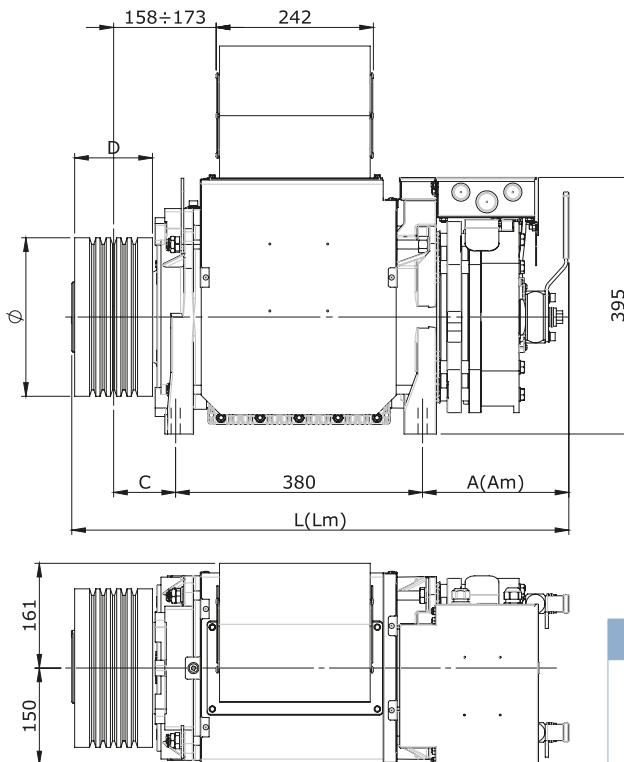

Dimensioni / Dimensions [mm]

A	L	Am**	Lm**	C	D	Ø
178	718	223	763	90.5	90	120 - 140 - 160 - 210 - 240
	726		771	105.5	120	120 - 140 - 160
	726		771	95.5	120	210 - 240 - 320 - 360 - 400
	751		796	110.5	150	240 - 320 - 360 - 400

* Per un maggiore ciclo di lavoro rispetto allo standard. Chiedere all'ufficio commerciale per maggiori informazioni.

For increased duty-cycle than the standard. Contact Sales dept. for further information.

** Quote con manovra apertura a mano. / Dimensions with lever for hand release.

G-300 TC Senza ventole di raffreddamento / Without cooling fans

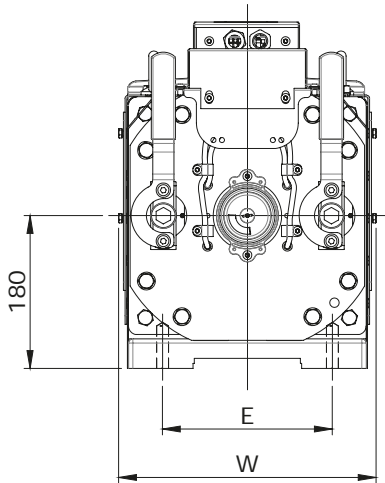

Encoder montato sul lato freno
Encoder mounted on the brake side

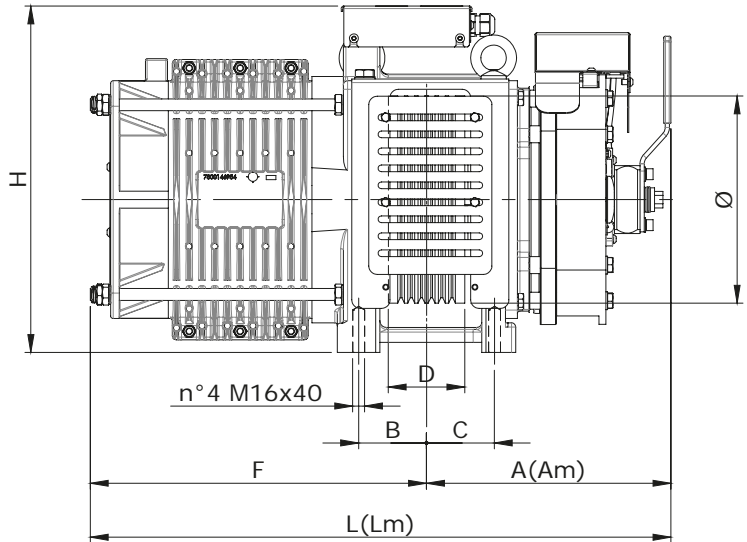

Unica direzione per l'uscita delle funi
Single direction rope exit

Dimensioni / Dimensions [mm]

A	L	Am*	Lm*	B	C	E	F	W	H	D	Ø
245	640	290	685	80	80	200	400	305	410	90	120 - 140 - 160- 210 - 240
				87.5	72.5					105	120 - 140 - 160

* Quote con manovra apertura a mano. / Dimensions with lever for hand release.

G-300 TC Con ventole di raffreddamento / With cooling fans

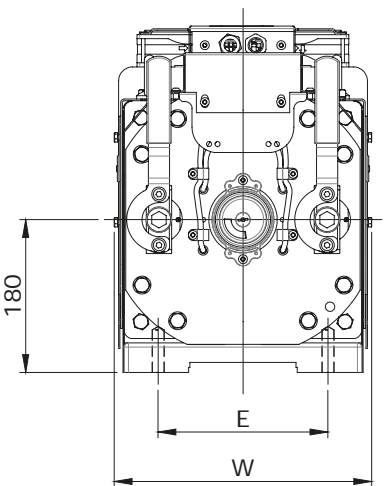

Encoder montato sul lato freno
Encoder mounted on the brake side

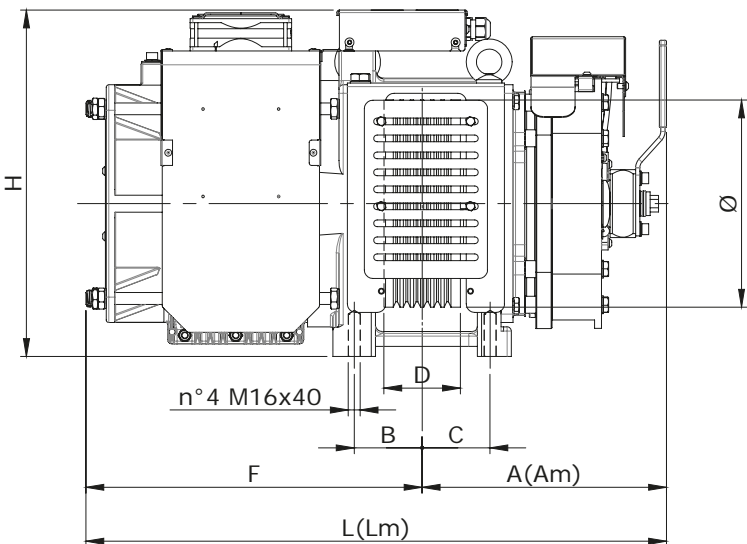

Unica direzione per l'uscita delle funi
Single direction rope exit

Dimensioni / Dimensions [mm]

A	L	Am*	Lm*	B	C	E	F	W	H	D	Ø
245	640	290	685	80	80	200	400	305	410	90	120 - 140 - 160- 210 - 240
				87.5	72.5					105	120 - 140 - 160

* Quote con manovra apertura a mano. / Dimensions with lever for hand release.

**G-300 TO · TC**

Tiro	Peso funi max	Portata	Velocità cabina	Ø Puleggia	Poli	Velocità	Frequenza	Efficienza vano	Coppia	Potenza in uscita
Roping	Max Ropes Weight	Duty Load	Cabin Speed	Sheave Diameter	Poles	Speed	Frequency	Shaft Efficiency	Torque	Power Output
	[kg]	[kg]	[m/s]	[mm]		[rpm]	[Hz]		[Nm]	[kW]
1	30	225	0,63	120	16	100,3	13,37	0,85	99	1,0
1	30	225	0,63	140	16	85,9	11,46	0,85	115	1,0
1	30	225	0,63	160	16	75,2	10,03	0,85	132	1,0
1	30	225	0,63	210	16	57,3	7,64	0,85	173	1,0
1	30	225	0,63	240	16	50,1	6,68	0,85	197	1,0
1	30	225	0,63	320 *	16	37,6	5,01	0,85	263	1,0
1	30	225	0,8	120	16	127,3	16,98	0,85	99	1,3
1	30	225	0,8	140	16	109,1	14,55	0,85	115	1,3
1	30	225	0,8	160	16	95,5	12,73	0,85	132	1,3
1	30	225	0,8	210	16	72,8	9,70	0,85	173	1,3
1	30	225	0,8	240	16	63,7	8,49	0,85	197	1,3
1	30	225	0,8	320 *	16	47,7	6,37	0,85	263	1,3
1	30	225	1	120	16	159,2	21,22	0,85	99	1,6
1	30	225	1	140	16	136,4	18,19	0,85	115	1,6
1	30	225	1	160	16	119,4	15,92	0,85	132	1,6
1	30	225	1	210	16	90,9	12,13	0,85	173	1,6
1	30	225	1	240	16	79,6	10,61	0,85	197	1,6
1	30	225	1	320 *	16	59,7	7,96	0,85	263	1,6
1	30	225	1,6	120	16	254,6	33,95	0,85	99	2,6
1	30	225	1,6	140	16	218,3	29,10	0,85	115	2,6
1	30	225	1,6	160	16	191,0	25,46	0,85	132	2,6
1	30	225	1,6	210	16	145,5	19,40	0,85	173	2,6
1	30	225	1,6	240	16	127,3	16,98	0,85	197	2,6
1	30	225	1,6	320 *	16	95,5	12,73	0,85	263	2,6
1	30	300	0,63	120	16	100,3	13,37	0,85	125	1,3
1	30	300	0,63	140	16	85,9	11,46	0,85	145	1,3
1	30	300	0,63	160	16	75,2	10,03	0,85	166	1,3
1	30	300	0,63	210	16	57,3	7,64	0,85	218	1,3
1	30	300	0,63	240	16	50,1	6,68	0,85	249	1,3
1	30	300	0,8	120	16	127,3	16,98	0,85	125	1,7
1	30	300	0,8	140	16	109,1	14,55	0,85	145	1,7
1	30	300	0,8	160	16	95,5	12,73	0,85	166	1,7
1	30	300	0,8	210	16	72,8	9,70	0,85	218	1,7
1	30	300	0,8	240	16	63,7	8,49	0,85	249	1,7
1	30	300	1	120	16	159,2	21,22	0,85	125	2,1
1	30	300	1	140	16	136,4	18,19	0,85	145	2,1
1	30	300	1	160	16	119,4	15,92	0,85	166	2,1
1	30	300	1	210	16	90,9	12,13	0,85	218	2,1
1	30	300	1	240	16	79,6	10,61	0,85	249	2,1
1	30	300	1,6	120	16	254,6	33,95	0,85	125	3,3
1	30	300	1,6	140	16	218,3	29,10	0,85	145	3,3
1	30	300	1,6	160	16	191,0	25,46	0,85	166	3,3
1	30	300	1,6	210	16	145,5	19,40	0,85	218	3,3
1	30	300	1,6	240	16	127,3	16,98	0,85	249	3,3



Tiro	Peso funi max	Portata	Velocità cabina	Ø Puleggia	Poli	Velocità	Frequenza	Efficienza vano	Coppia	Potenza in uscita
Roping	Max Ropes Weight	Duty Load	Cabin Speed	Sheave Diameter	Poles	Speed	Frequency	Shaft Efficiency	Torque	Power Output
	[kg]	[kg]	[m/s]	[mm]		[rpm]	[Hz]		[Nm]	[kW]
1	30	375	0,63	120	16	100,3	13,37	0,85	151	1,6
1	30	375	0,63	140	16	85,9	11,46	0,85	176	1,6
1	30	375	0,63	160	16	75,2	10,03	0,85	201	1,6
1	30	375	0,63	210	16	57,3	7,64	0,85	264	1,6
1	30	375	0,8	120	16	127,3	16,98	0,85	151	2,0
1	30	375	0,8	140	16	109,1	14,55	0,85	176	2,0
1	30	375	0,8	160	16	95,5	12,73	0,85	201	2,0
1	30	375	0,8	210	16	72,8	9,70	0,85	264	2,0
1	30	375	1	120	16	159,2	21,22	0,85	151	2,5
1	30	375	1	140	16	136,4	18,19	0,85	176	2,5
1	30	375	1	160	16	119,4	15,92	0,85	201	2,5
1	30	375	1	210	16	90,9	12,13	0,85	264	2,5
1	30	375	1,6	120	16	254,6	33,95	0,85	151	4,0
1	30	375	1,6	140	16	218,3	29,10	0,85	176	4,0
1	30	375	1,6	160	16	191,0	25,46	0,85	201	4,0
1	30	375	1,6	210	16	145,5	19,40	0,85	264	4,0
1	30	450	0,63	120	16	100,3	13,37	0,85	177	1,9
1	30	450	0,63	140	16	85,9	11,46	0,85	206	1,9
1	30	450	0,63	160	16	75,2	10,03	0,85	235	1,9
1	30	450	0,8	120	16	127,3	16,98	0,85	177	2,4
1	30	450	0,8	140	16	109,1	14,55	0,85	206	2,4
1	30	450	0,8	160	16	95,5	12,73	0,85	235	2,4
1	30	450	1	120	16	159,2	21,22	0,85	177	2,9
1	30	450	1	140	16	136,4	18,19	0,85	206	2,9
1	30	450	1	160	16	119,4	15,92	0,85	235	2,9
1	30	450	1,6	120	16	254,6	33,95	0,85	177	4,7
1	30	450	1,6	140	16	218,3	29,10	0,85	206	4,7
1	30	450	1,6	160	16	191,0	25,46	0,85	235	4,7
1	30	525	0,63	120	16	100,3	13,37	0,85	203	2,1
1	30	525	0,63	140	16	85,9	11,46	0,85	236	2,1
1	30	525	0,63	160	16	75,2	10,03	0,85	270	2,1
1	30	525	0,8	120	16	127,3	16,98	0,85	203	2,7
1	30	525	0,8	140	16	109,1	14,55	0,85	236	2,7
1	30	525	0,8	160	16	95,5	12,73	0,85	270	2,7
1	30	525	1	120	16	159,2	21,22	0,85	203	3,4
1	30	525	1	140	16	136,4	18,19	0,85	236	3,4
1	30	525	1	160	16	119,4	15,92	0,85	270	3,4
1	30	525	1,6	120	16	254,6	33,95	0,85	203	5,4
1	30	525	1,6	140	16	218,3	29,10	0,85	236	5,4
1	30	525	1,6	160	16	191,0	25,46	0,85	270	5,4
1	30	630	0,63	120	16	100,3	13,37	0,85	239	2,5
1	30	630	0,8	120	16	127,3	16,98	0,85	239	3,2
1	30	630	1	120	16	159,2	21,22	0,85	239	4,0
1	30	630	1,6	120	16	254,6	33,95	0,85	239	6,4
2	30	300	0,63	120	16	200,5	26,74	0,85	73	1,5
2	30	300	0,63	140	16	171,9	22,92	0,85	85	1,5
2	30	300	0,63	160	16	150,4	20,05	0,85	97	1,5
2	30	300	0,63	210	16	114,6	15,28	0,85	127	1,5

Tiro	Peso funi max	Portata	Velocità cabina	Ø Puleggia	Poli	Velocità	Frequenza	Efficienza vano	Coppia	Potenza in uscita
Roping	Max Ropes Weight	Duty Load	Cabin Speed	Sheave Diameter	Poles	Speed	Frequency	Shaft Efficiency	Torque	Power Output
	[kg]	[kg]	[m/s]	[mm]		[rpm]	[Hz]		[Nm]	[kW]
2	30	300	0,63	240	16	100,3	13,37	0,85	145	1,5
2	30	300	0,63	320 *	16	75,2	10,03	0,85	194	1,5
2	30	300	0,63	360 *	16	66,8	8,91	0,85	218	1,5
2	30	300	0,63	400 *	16	60,2	8,02	0,85	242	1,5
2	30	300	0,8	120	16	254,6	33,95	0,85	73	1,9
2	30	300	0,8	140	16	218,3	29,10	0,85	85	1,9
2	30	300	0,8	160	16	191,0	25,46	0,85	97	1,9
2	30	300	0,8	210	16	145,5	19,40	0,85	127	1,9
2	30	300	0,8	240	16	127,3	16,98	0,85	145	1,9
2	30	300	0,8	320 *	16	95,5	12,73	0,85	194	1,9
2	30	300	0,8	360 *	16	84,9	11,32	0,85	218	1,9
2	30	300	0,8	400 *	16	76,4	10,19	0,85	242	1,9
2	30	300	1	120	16	318,3	42,44	0,85	73	2,4
2	30	300	1	140	16	272,8	36,38	0,85	85	2,4
2	30	300	1	160	16	238,7	31,83	0,85	97	2,4
2	30	300	1	210	16	181,9	24,25	0,85	127	2,4
2	30	300	1	240	16	159,2	21,22	0,85	145	2,4
2	30	300	1	320 *	16	119,4	15,92	0,85	194	2,4
2	30	300	1	360 *	16	106,1	14,15	0,85	218	2,4
2	30	300	1	400 *	16	95,5	12,73	0,85	242	2,4
2	30	300	1,6	210	16	291,0	38,80	0,85	127	3,9
2	30	300	1,6	240	16	254,6	33,95	0,85	145	3,9
2	30	300	1,6	320 *	16	191,0	25,46	0,85	194	3,9
2	30	300	1,6	360 *	16	169,8	22,64	0,85	218	3,9
2	30	300	1,6	400 *	16	152,8	20,37	0,85	242	3,9
2	30	375	0,63	120	16	200,5	26,74	0,85	86	1,8
2	30	375	0,63	140	16	171,9	22,92	0,85	100	1,8
2	30	375	0,63	160	16	150,4	20,05	0,85	114	1,8
2	30	375	0,63	210	16	114,6	15,28	0,85	150	1,8
2	30	375	0,63	240	16	100,3	13,37	0,85	171	1,8
2	30	375	0,63	320 *	16	75,2	10,03	0,85	229	1,8
2	30	375	0,63	360 *	16	66,8	8,91	0,85	257	1,8
2	30	375	0,8	120	16	254,6	33,95	0,85	86	2,3
2	30	375	0,8	140	16	218,3	29,10	0,85	100	2,3
2	30	375	0,8	160	16	191,0	25,46	0,85	114	2,3
2	30	375	0,8	210	16	145,5	19,40	0,85	150	2,3
2	30	375	0,8	240	16	127,3	16,98	0,85	171	2,3
2	30	375	0,8	320 *	16	95,5	12,73	0,85	229	2,3
2	30	375	0,8	360 *	16	84,9	11,32	0,85	257	2,3
2	30	375	1	120	16	318,3	42,44	0,85	86	2,9
2	30	375	1	140	16	272,8	36,38	0,85	100	2,9
2	30	375	1	160	16	238,7	31,83	0,85	114	2,9
2	30	375	1	210	16	181,9	24,25	0,85	150	2,9
2	30	375	1	240	16	159,2	21,22	0,85	171	2,9
2	30	375	1	320 *	16	119,4	15,92	0,85	229	2,9
2	30	375	1	360 *	16	106,1	14,15	0,85	257	2,9
2	30	375	1,6	210	16	291,0	38,80	0,85	150	4,6
2	30	375	1,6	240	16	254,6	33,95	0,85	171	4,6

Tiro	Peso funi max	Portata	Velocità cabina	Ø Puleggia	Poli	Velocità	Frequenza	Efficienza vano	Coppia	Potenza in uscita
Roping	Max Ropes Weight	Duty Load	Cabin Speed	Sheave Diameter	Poles	Speed	Frequency	Shaft Efficiency	Torque	Power Output
	[kg]	[kg]	[m/s]	[mm]		[rpm]	[Hz]		[Nm]	[kW]
2	30	375	1,6	320 *	16	191,0	25,46	0,85	229	4,6
2	30	375	1,6	360 *	16	169,8	22,64	0,85	257	4,6
2	30	450	0,63	120	16	200,5	26,74	0,85	99	2,1
2	30	450	0,63	140	16	171,9	22,92	0,85	115	2,1
2	30	450	0,63	160	16	150,4	20,05	0,85	132	2,1
2	30	450	0,63	210	16	114,6	15,28	0,85	173	2,1
2	30	450	0,63	240	16	100,3	13,37	0,85	197	2,1
2	30	450	0,63	320 *	16	75,2	10,03	0,85	263	2,1
2	30	450	0,8	120	16	254,6	33,95	0,85	99	2,6
2	30	450	0,8	140	16	218,3	29,10	0,85	115	2,6
2	30	450	0,8	160	16	191,0	25,46	0,85	132	2,6
2	30	450	0,8	210	16	145,5	19,40	0,85	173	2,6
2	30	450	0,8	240	16	127,3	16,98	0,85	197	2,6
2	30	450	0,8	320 *	16	95,5	12,73	0,85	263	2,6
2	30	450	1	120	16	318,3	42,44	0,85	99	3,3
2	30	450	1	140	16	272,8	36,38	0,85	115	3,3
2	30	450	1	160	16	238,7	31,83	0,85	132	3,3
2	30	450	1	210	16	181,9	24,25	0,85	173	3,3
2	30	450	1	240	16	159,2	21,22	0,85	197	3,3
2	30	450	1	320 *	16	119,4	15,92	0,85	263	3,3
2	30	450	1,6	210	16	291,0	38,80	0,85	173	5,3
2	30	450	1,6	240	16	254,6	33,95	0,85	197	5,3
2	30	450	1,6	320 *	16	191,0	25,46	0,85	263	5,3
2	30	525	0,63	120	16	200,5	26,74	0,85	112	2,3
2	30	525	0,63	140	16	171,9	22,92	0,85	130	2,3
2	30	525	0,63	160	16	150,4	20,05	0,85	149	2,3
2	30	525	0,63	210	16	114,6	15,28	0,85	195	2,3
2	30	525	0,63	240	16	100,3	13,37	0,85	223	2,3
2	30	525	0,8	120	16	254,6	33,95	0,85	112	3,0
2	30	525	0,8	140	16	218,3	29,10	0,85	130	3,0
2	30	525	0,8	160	16	191,0	25,46	0,85	149	3,0
2	30	525	0,8	210	16	145,5	19,40	0,85	195	3,0
2	30	525	0,8	240	16	127,3	16,98	0,85	223	3,0
2	30	525	1	120	16	318,3	42,44	0,85	112	3,7
2	30	525	1	140	16	272,8	36,38	0,85	130	3,7
2	30	525	1	160	16	238,7	31,83	0,85	149	3,7
2	30	525	1	210	16	181,9	24,25	0,85	195	3,7
2	30	525	1	240	16	159,2	21,22	0,85	223	3,7
2	30	525	1,6	210	16	291,0	38,80	0,85	195	6,0
2	30	525	1,6	240	16	254,6	33,95	0,85	223	6,0
2	30	630	0,63	120	16	200,5	26,74	0,85	130	2,7
2	30	630	0,63	140	16	171,9	22,92	0,85	151	2,7
2	30	630	0,63	160	16	150,4	20,05	0,85	173	2,7
2	30	630	0,63	210	16	114,6	15,28	0,85	227	2,7
2	30	630	0,63	240	16	100,3	13,37	0,85	260	2,7
2	30	630	0,8	120	16	254,6	33,95	0,85	130	3,5
2	30	630	0,8	140	16	218,3	29,10	0,85	151	3,5
2	30	630	0,8	160	16	191,0	25,46	0,85	173	3,5

Tiro	Peso funi max	Portata	Velocità cabina	Ø Puleggia	Poli	Velocità	Frequenza	Efficienza vano	Coppia	Potenza in uscita
Roping	Max Ropes Weight	Duty Load	Cabin Speed	Sheave Diameter	Poles	Speed	Frequency	Shaft Efficiency	Torque	Power Output
	[kg]	[kg]	[m/s]	[mm]		[rpm]	[Hz]		[Nm]	[kW]
2	30	630	0,8	210	16	145,5	19,40	0,85	227	3,5
2	30	630	0,8	240	16	127,3	16,98	0,85	260	3,5
2	30	630	1	120	16	318,3	42,44	0,85	130	4,3
2	30	630	1	140	16	272,8	36,38	0,85	151	4,3
2	30	630	1	160	16	238,7	31,83	0,85	173	4,3
2	30	630	1	210	16	181,9	24,25	0,85	227	4,3
2	30	630	1	240	16	159,2	21,22	0,85	260	4,3
2	30	630	1,6	210	16	291,0	38,80	0,85	227	6,9
2	30	630	1,6	240	16	254,6	33,95	0,85	260	6,9
2	30	750	0,63	120	16	200,5	26,74	0,85	151	3,2
2	30	750	0,63	140	16	171,9	22,92	0,85	176	3,2
2	30	750	0,63	160	16	150,4	20,05	0,85	201	3,2
2	30	750	0,63	210	16	114,6	15,28	0,85	264	3,2
2	30	750	0,8	120	16	254,6	33,95	0,85	151	4,0
2	30	750	0,8	140	16	218,3	29,10	0,85	176	4,0
2	30	750	0,8	160	16	191,0	25,46	0,85	201	4,0
2	30	750	0,8	210	16	145,5	19,40	0,85	264	4,0
2	30	750	1	120	16	318,3	42,44	0,85	151	5,0
2	30	750	1	140	16	272,8	36,38	0,85	176	5,0
2	30	750	1	160	16	238,7	31,83	0,85	201	5,0
2	30	750	1	210	16	181,9	24,25	0,85	264	5,0
2	30	750	1,6	210	16	291,0	38,80	0,85	264	8,0
2	30	800	0,63	120	16	200,5	26,74	0,85	159	3,3
2	30	800	0,63	140	16	171,9	22,92	0,85	186	3,3
2	30	800	0,63	160	16	150,4	20,05	0,85	212	3,3
2	30	800	0,8	120	16	254,6	33,95	0,85	159	4,2
2	30	800	0,8	140	16	218,3	29,10	0,85	186	4,2
2	30	800	0,8	160	16	191,0	25,46	0,85	212	4,2
2	30	800	1	120	16	318,3	42,44	0,85	159	5,3
2	30	800	1	140	16	272,8	36,38	0,85	186	5,3
2	30	800	1	160	16	238,7	31,83	0,85	212	5,3

Note 1

Note 2

Note 3

max 270

G-300 T0 · TC | Note / Notes

- Brake Type:** G-300 T0: DF01, Standard 205 V D. Other voltages on request.
G-300 TC: DFA1, Standard 205 V DC. Other voltages on request.
DFXY certified brake against Overspeed in upward direction and as UCM (EN 81-20:2020, EN 81-50:2020) with reference to Lift Directive 2014/33/EU.
- Encoder Type:** Absolute encoder with EnDat Interface or Incremental sin/cos, both with 2048 ppr
- Duty-cycle:** Max 240 sts/h - 40% ED without fans.
Max 240 sts/h - 50% ED with fans activated by thermocontacts inside motor.
- Traction sheave:** G-300 T0: Traction sheave width 120 mm. Available width 150 mm for Ø240, Ø320, Ø360 and Ø400.
G-300 TC: Traction sheave width 90 mm. Available width 105 mm for Ø120, Ø140, Ø160 mm.
- * Sheave diameter available only for G-300 T0.

- Note 1:** For higher ropes weight, please consult sales/technical services of Alberto Sassi SpA.
- Note 2:** Details on ropes/grooves provided upon lift data. Suitable for steel core ropes or also for plastic coated ropes.
- Note 3:** Shaft efficiency includes divertor pulleys efficiency by considering: 3 divertors for roping 2:1. Values are supposed.

G-300 TS · TC

Tiro	Peso funi max	Portata	Velocità cabina	Ø Puleggia	Poli	Velocità	Frequenza	Efficienza vano	Coppia	Potenza in uscita
Roping	Max Ropes Weight	Duty Load	Cabin Speed	Sheave Diameter	Poles	Speed	Frequency	Shaft Efficiency	Torque	Power Output
	[kg]	[kg]	[m/s]	[mm]		[rpm]	[Hz]		[Nm]	[kW]
1	30	450	0,63	210	16	57,3	7,64	0,85	309	1,9
1	30	450	0,8	210	16	72,8	9,70	0,85	309	2,4
1	30	450	1	210	16	90,9	12,13	0,85	309	2,9
1	30	450	1,6	210	16	145,5	19,40	0,85	309	4,7
1	30	630	0,63	120	16	100,3	13,37	0,85	239	2,5
1	30	630	0,63	140	16	85,9	11,46	0,85	279	2,5
1	30	630	0,63	160	16	75,2	10,03	0,85	319	2,5
1	30	630	0,8	120	16	127,3	16,98	0,85	239	3,2
1	30	630	0,8	140	16	109,1	14,55	0,85	279	3,2
1	30	630	0,8	160	16	95,5	12,73	0,85	319	3,2
1	30	630	1	120	16	159,2	21,22	0,85	239	4,0
1	30	630	1	140	16	136,4	18,19	0,85	279	4,0
1	30	630	1	160	16	119,4	15,92	0,85	319	4,0
1	30	630	1,6	120	16	254,6	33,95	0,85	239	6,4
1	30	630	1,6	140	16	218,3	29,10	0,85	279	6,4
1	30	630	1,6	160	16	191,0	25,46	0,85	319	6,4
1	30	800	0,63	120	16	100,3	13,37	0,85	298	3,1
1	30	800	0,8	120	16	127,3	16,98	0,85	298	4,0
1	30	800	1	120	16	159,2	21,22	0,85	298	5,0
1	30	800	1,6	120	16	254,6	33,95	0,85	298	7,9
2	30	450	0,63	360 *	16	66,8	8,91	0,85	296	2,1
2	30	450	0,8	360 *	16	84,9	11,32	0,85	296	2,6
2	30	450	1	360 *	16	106,1	14,15	0,85	296	3,3
2	30	450	1,6	360 *	16	169,8	22,64	0,85	296	5,3
2	30	630	0,63	240	16	100,3	13,37	0,85	260	2,7
2	30	630	0,8	240	16	127,3	16,98	0,85	260	3,5
2	30	630	1	240	16	159,2	21,22	0,85	260	4,3
2	30	630	1,6	240	16	254,6	33,95	0,85	260	6,9
2	30	800	0,63	210	16	114,6	15,28	0,85	279	3,3
2	30	800	0,63	240	16	100,3	13,37	0,85	319	3,3
2	30	800	0,8	210	16	145,5	19,40	0,85	279	4,2
2	30	800	0,8	240	16	127,3	16,98	0,85	319	4,2
2	30	800	1	210	16	181,9	24,25	0,85	279	5,3
2	30	800	1	240	16	159,2	21,22	0,85	319	5,3
2	30	800	1,6	210	16	291,0	38,80	0,85	279	8,5
2	30	800	1,6	240	16	254,6	33,95	0,85	319	8,5

Note 1

Note 2

Note 3

max 320

G-300 TS · TC | Note / Notes

Brake Type: G-300 TS: DF01, Standard 205 V DC. Other voltages on request.
G-300 TC: DFA1, Standard 205 V DC. Other voltages on request.
DFXY certified brake against Overspeed in upward direction and as UCM (EN 81-20:2020, EN 81-50:2020) with reference to Lift Directive 2014/33/EU.

Encoder Type: Absolute encoder with EnDat Interface or Incremental sin/cos, both with 2048 ppr

Duty-cycle: Max 180 sts/h - 40% ED with fans activated by thermocontacts inside motor.

Traction sheave: G-300 TS: Traction sheave width 120 mm. Available width 150 mm for Ø240, Ø320, Ø360 and Ø400.
G-300 TC: Traction sheave width 90 mm. Available width 105 mm for Ø120, Ø140, Ø160 mm.

* Sheave diameter available only for G-300 TS.

Note 1: For higher ropes weight, please consult sales/technical services of Alberto Sassi SpA.

Note 2: Details on ropes/grooves provided upon lift data. Suitable for steel core ropes or also for plastic coated ropes.

Note 3: Shaft efficiency includes divertor pulleys efficiency by considering: 3 divertors for roping 2:1. Values are supposed.

G-300 T1

Tiro	Peso funi max	Portata	Velocità cabina	Ø Puleggia	Poli	Velocità	Frequenza	Efficienza vano	Coppia	Potenza in uscita
Roping	Max Ropes Weight	Duty Load	Cabin Speed	Sheave Diameter	Poles	Speed	Frequency	Shaft Efficiency	Torque	Power Output
	[kg]	[kg]	[m/s]	[mm]		[rpm]	[Hz]		[Nm]	[kW]
1	30	300	0,63	120	16	100,3	13,37	0,85	125	1,3
1	30	300	0,63	140	16	85,9	11,46	0,85	145	1,3
1	30	300	0,63	160	16	75,2	10,03	0,85	166	1,3
1	30	300	0,63	210	16	57,3	7,64	0,85	218	1,3
1	30	300	0,63	240	16	50,1	6,68	0,85	249	1,3
1	30	300	0,63	320	16	37,6	5,01	0,85	332	1,3
1	30	300	0,8	120	16	127,3	16,98	0,85	125	1,7
1	30	300	0,8	140	16	109,1	14,55	0,85	145	1,7
1	30	300	0,8	160	16	95,5	12,73	0,85	166	1,7
1	30	300	0,8	210	16	72,8	9,70	0,85	218	1,7
1	30	300	0,8	240	16	63,7	8,49	0,85	249	1,7
1	30	300	0,8	320	16	47,7	6,37	0,85	332	1,7
1	30	300	0,8	360	16	42,4	5,66	0,85	374	1,7
1	30	300	0,8	400	16	38,2	5,09	0,85	415	1,7
1	30	300	1	120	16	159,2	21,22	0,85	125	2,1
1	30	300	1	140	16	136,4	18,19	0,85	145	2,1
1	30	300	1	160	16	119,4	15,92	0,85	166	2,1
1	30	300	1	210	16	90,9	12,13	0,85	218	2,1
1	30	300	1	240	16	79,6	10,61	0,85	249	2,1
1	30	300	1	320	16	59,7	7,96	0,85	332	2,1
1	30	300	1	360	16	53,1	7,07	0,85	374	2,1
1	30	300	1	400	16	47,7	6,37	0,85	415	2,1
1	30	300	1,6	120	16	254,6	33,95	0,85	125	3,3
1	30	300	1,6	140	16	218,3	29,10	0,85	145	3,3
1	30	300	1,6	160	16	191,0	25,46	0,85	166	3,3
1	30	300	1,6	210	16	145,5	19,40	0,85	218	3,3
1	30	300	1,6	240	16	127,3	16,98	0,85	249	3,3
1	30	300	1,6	320	16	95,5	12,73	0,85	332	3,3
1	30	300	1,6	360	16	84,9	11,32	0,85	374	3,3
1	30	300	1,6	400	16	76,4	10,19	0,85	415	3,3
1	30	375	0,63	120	16	100,3	13,37	0,85	151	1,6
1	30	375	0,63	140	16	85,9	11,46	0,85	176	1,6
1	30	375	0,63	160	16	75,2	10,03	0,85	201	1,6
1	30	375	0,63	210	16	57,3	7,64	0,85	264	1,6
1	30	375	0,63	240	16	50,1	6,68	0,85	301	1,6
1	30	375	0,63	320	16	37,6	5,01	0,85	402	1,6
1	30	375	0,8	120	16	127,3	16,98	0,85	151	2,0
1	30	375	0,8	140	16	109,1	14,55	0,85	176	2,0
1	30	375	0,8	160	16	95,5	12,73	0,85	201	2,0
1	30	375	0,8	210	16	72,8	9,70	0,85	264	2,0
1	30	375	0,8	240	16	63,7	8,49	0,85	301	2,0
1	30	375	0,8	320	16	47,7	6,37	0,85	402	2,0
1	30	375	1	120	16	159,2	21,22	0,85	151	2,5
1	30	375	1	140	16	136,4	18,19	0,85	176	2,5
1	30	375	1	160	16	119,4	15,92	0,85	201	2,5
1	30	375	1	210	16	90,9	12,13	0,85	264	2,5
1	30	375	1	240	16	79,6	10,61	0,85	301	2,5
1	30	375	1	320	16	59,7	7,96	0,85	402	2,5
1	30	375	1,6	120	16	254,6	33,95	0,85	151	4,0

Tiro	Peso funi max	Portata	Velocità cabina	Ø Puleggia	Poli	Velocità	Frequenza	Efficienza vano	Coppia	Potenza in uscita
Roping	Max Ropes Weight	Duty Load	Cabin Speed	Sheave Diameter	Poles	Speed	Frequency	Shaft Efficiency	Torque	Power Output
	[kg]	[kg]	[m/s]	[mm]		[rpm]	[Hz]		[Nm]	[kW]
1	30	375	1,6	140	16	218,3	29,10	0,85	176	4,0
1	30	375	1,6	160	16	191,0	25,46	0,85	201	4,0
1	30	375	1,6	210	16	145,5	19,40	0,85	264	4,0
1	30	375	1,6	240	16	127,3	16,98	0,85	301	4,0
1	30	375	1,6	320	16	95,5	12,73	0,85	402	4,0
1	30	400	0,63	120	16	100,3	13,37	0,85	159	1,7
1	30	400	0,63	140	16	85,9	11,46	0,85	186	1,7
1	30	400	0,63	160	16	75,2	10,03	0,85	212	1,7
1	30	400	0,63	210	16	57,3	7,64	0,85	279	1,7
1	30	400	0,63	240	16	50,1	6,68	0,85	319	1,7
1	30	400	0,63	320	16	37,6	5,01	0,85	425	1,7
1	30	400	0,8	120	16	127,3	16,98	0,85	159	2,1
1	30	400	0,8	140	16	109,1	14,55	0,85	186	2,1
1	30	400	0,8	160	16	95,5	12,73	0,85	212	2,1
1	30	400	0,8	210	16	72,8	9,70	0,85	279	2,1
1	30	400	0,8	240	16	63,7	8,49	0,85	319	2,1
1	30	400	0,8	320	16	47,7	6,37	0,85	425	2,1
1	30	400	1	120	16	159,2	21,22	0,85	159	2,7
1	30	400	1	140	16	136,4	18,19	0,85	186	2,7
1	30	400	1	160	16	119,4	15,92	0,85	212	2,7
1	30	400	1	210	16	90,9	12,13	0,85	279	2,7
1	30	400	1	240	16	79,6	10,61	0,85	319	2,7
1	30	400	1	320	16	59,7	7,96	0,85	425	2,7
1	30	400	1,6	120	16	254,6	33,95	0,85	159	4,2
1	30	400	1,6	140	16	218,3	29,10	0,85	186	4,2
1	30	400	1,6	160	16	191,0	25,46	0,85	212	4,2
1	30	400	1,6	210	16	145,5	19,40	0,85	279	4,2
1	30	400	1,6	240	16	127,3	16,98	0,85	319	4,2
1	30	400	1,6	320	16	95,5	12,73	0,85	425	4,2
1	30	450	0,63	120	16	100,3	13,37	0,85	177	1,9
1	30	450	0,63	140	16	85,9	11,46	0,85	206	1,9
1	30	450	0,63	160	16	75,2	10,03	0,85	235	1,9
1	30	450	0,63	210	16	57,3	7,64	0,85	309	1,9
1	30	450	0,63	240	16	50,1	6,68	0,85	353	1,9
1	30	450	0,8	120	16	127,3	16,98	0,85	177	2,4
1	30	450	0,8	140	16	109,1	14,55	0,85	206	2,4
1	30	450	0,8	160	16	95,5	12,73	0,85	235	2,4
1	30	450	0,8	210	16	72,8	9,70	0,85	309	2,4
1	30	450	0,8	240	16	63,7	8,49	0,85	353	2,4
1	30	450	1	120	16	159,2	21,22	0,85	177	2,9
1	30	450	1	140	16	136,4	18,19	0,85	206	2,9
1	30	450	1	160	16	119,4	15,92	0,85	235	2,9
1	30	450	1	210	16	90,9	12,13	0,85	309	2,9
1	30	450	1	240	16	79,6	10,61	0,85	353	2,9
1	30	450	1,6	120	16	254,6	33,95	0,85	177	4,7
1	30	450	1,6	140	16	218,3	29,10	0,85	206	4,7
1	30	450	1,6	160	16	191,0	25,46	0,85	235	4,7
1	30	450	1,6	210	16	145,5	19,40	0,85	309	4,7
1	30	450	1,6	240	16	127,3	16,98	0,85	353	4,7
1	30	630	0,63	120	16	100,3	13,37	0,85	239	2,5

Tiro	Peso funi max	Portata	Velocità cabina	Ø Puleggia	Poli	Velocità	Frequenza	Efficienza vano	Coppia	Potenza in uscita
Roping	Max Ropes Weight	Duty Load	Cabin Speed	Sheave Diameter	Poles	Speed	Frequency	Shaft Efficiency	Torque	Power Output
	[kg]	[kg]	[m/s]	[mm]		[rpm]	[Hz]		[Nm]	[kW]
1	30	630	0,63	140	16	85,9	11,46	0,85	279	2,5
1	30	630	0,63	160	16	75,2	10,03	0,85	319	2,5
1	30	630	0,63	210	16	57,3	7,64	0,85	418	2,5
1	30	630	0,8	120	16	127,3	16,98	0,85	239	3,2
1	30	630	0,8	140	16	109,1	14,55	0,85	279	3,2
1	30	630	0,8	160	16	95,5	12,73	0,85	319	3,2
1	30	630	0,8	210	16	72,8	9,70	0,85	418	3,2
1	30	630	1	120	16	159,2	21,22	0,85	239	4,0
1	30	630	1	140	16	136,4	18,19	0,85	279	4,0
1	30	630	1	160	16	119,4	15,92	0,85	319	4,0
1	30	630	1	210	16	90,9	12,13	0,85	418	4,0
1	30	630	1,6	120	16	254,6	33,95	0,85	239	6,4
1	30	630	1,6	140	16	218,3	29,10	0,85	279	6,4
1	30	630	1,6	160	16	191,0	25,46	0,85	319	6,4
1	30	630	1,6	210	16	145,5	19,40	0,85	418	6,4
1	30	800	0,63	120	16	100,3	13,37	0,85	298	3,1
1	30	800	0,63	140	16	85,9	11,46	0,85	347	3,1
1	30	800	0,63	160	16	75,2	10,03	0,85	397	3,1
1	30	800	0,8	120	16	127,3	16,98	0,85	298	4,0
1	30	800	0,8	140	16	109,1	14,55	0,85	347	4,0
1	30	800	0,8	160	16	95,5	12,73	0,85	397	4,0
1	30	800	1	120	16	159,2	21,22	0,85	298	5,0
1	30	800	1	140	16	136,4	18,19	0,85	347	5,0
1	30	800	1	160	16	119,4	15,92	0,85	397	5,0
1	30	800	1,6	120	16	254,6	33,95	0,85	298	7,9
1	30	800	1,6	140	16	218,3	29,10	0,85	347	7,9
1	30	800	1,6	160	16	191,0	25,46	0,85	397	7,9
2	30	450	0,63	120	16	200,5	26,74	0,85	99	2,1
2	30	450	0,63	140	16	171,9	22,92	0,85	115	2,1
2	30	450	0,63	160	16	150,4	20,05	0,85	132	2,1
2	30	450	0,63	210	16	114,6	15,28	0,85	173	2,1
2	30	450	0,63	240	16	100,3	13,37	0,85	197	2,1
2	30	450	0,63	320	16	75,2	10,03	0,85	263	2,1
2	30	450	0,63	360	16	66,8	8,91	0,85	296	2,1
2	30	450	0,63	400	16	60,2	8,02	0,85	329	2,1
2	30	450	0,8	120	16	254,6	33,95	0,85	99	2,6
2	30	450	0,8	140	16	218,3	29,10	0,85	115	2,6
2	30	450	0,8	160	16	191,0	25,46	0,85	132	2,6
2	30	450	0,8	210	16	145,5	19,40	0,85	173	2,6
2	30	450	0,8	240	16	127,3	16,98	0,85	197	2,6
2	30	450	0,8	320	16	95,5	12,73	0,85	263	2,6
2	30	450	0,8	360	16	84,9	11,32	0,85	296	2,6
2	30	450	0,8	400	16	76,4	10,19	0,85	329	2,6
2	30	450	1	120	16	318,3	42,44	0,85	99	3,3
2	30	450	1	140	16	272,8	36,38	0,85	115	3,3
2	30	450	1	160	16	238,7	31,83	0,85	132	3,3
2	30	450	1	210	16	181,9	24,25	0,85	173	3,3
2	30	450	1	240	16	159,2	21,22	0,85	197	3,3
2	30	450	1	320	16	119,4	15,92	0,85	263	3,3
2	30	450	1	360	16	106,1	14,15	0,85	296	3,3

Tiro	Peso funi max	Portata	Velocità cabina	Ø Puleggia	Poli	Velocità	Frequenza	Efficienza vano	Coppia	Potenza in uscita
Roping	Max Ropes Weight	Duty Load	Cabin Speed	Sheave Diameter	Poles	Speed	Frequency	Shaft Efficiency	Torque	Power Output
	[kg]	[kg]	[m/s]	[mm]		[rpm]	[Hz]		[Nm]	[kW]
2	30	450	1	400	16	95,5	12,73	0,85	329	3,3
2	30	450	1,6	210	16	291,0	38,80	0,85	173	5,3
2	30	450	1,6	240	16	254,6	33,95	0,85	197	5,3
2	30	450	1,6	320	16	191,0	25,46	0,85	263	5,3
2	30	450	1,6	360	16	169,8	22,64	0,85	296	5,3
2	30	450	1,6	400	16	152,8	20,37	0,85	329	5,3
2	30	630	0,63	120	16	200,5	26,74	0,85	130	2,7
2	30	630	0,63	140	16	171,9	22,92	0,85	151	2,7
2	30	630	0,63	160	16	150,4	20,05	0,85	173	2,7
2	30	630	0,63	210	16	114,6	15,28	0,85	227	2,7
2	30	630	0,63	240	16	100,3	13,37	0,85	260	2,7
2	30	630	0,63	320	16	75,2	10,03	0,85	346	2,7
2	30	630	0,63	360	16	66,8	8,91	0,85	390	2,7
2	30	630	0,8	120	16	254,6	33,95	0,85	130	3,5
2	30	630	0,8	140	16	218,3	29,10	0,85	151	3,5
2	30	630	0,8	160	16	191,0	25,46	0,85	173	3,5
2	30	630	0,8	210	16	145,5	19,40	0,85	227	3,5
2	30	630	0,8	240	16	127,3	16,98	0,85	260	3,5
2	30	630	0,8	320	16	95,5	12,73	0,85	346	3,5
2	30	630	0,8	360	16	84,9	11,32	0,85	390	3,5
2	30	630	1	120	16	318,3	42,44	0,85	130	4,3
2	30	630	1	140	16	272,8	36,38	0,85	151	4,3
2	30	630	1	160	16	238,7	31,83	0,85	173	4,3
2	30	630	1	210	16	181,9	24,25	0,85	227	4,3
2	30	630	1	240	16	159,2	21,22	0,85	260	4,3
2	30	630	1	320	16	119,4	15,92	0,85	346	4,3
2	30	630	1	360	16	106,1	14,15	0,85	390	4,3
2	30	630	1,6	210	16	291,0	38,80	0,85	227	6,9
2	30	630	1,6	240	16	254,6	33,95	0,85	260	6,9
2	30	630	1,6	320	16	191,0	25,46	0,85	346	6,9
2	30	630	1,6	360	16	169,8	22,64	0,85	390	6,9
2	30	800	0,63	120	16	200,5	26,74	0,85	159	3,3
2	30	800	0,63	140	16	171,9	22,92	0,85	186	3,3
2	30	800	0,63	160	16	150,4	20,05	0,85	212	3,3
2	30	800	0,63	210	16	114,6	15,28	0,85	279	3,3
2	30	800	0,63	240	16	100,3	13,37	0,85	319	3,3
2	30	800	0,63	320	16	75,2	10,03	0,85	425	3,3
2	30	800	0,8	120	16	254,6	33,95	0,85	159	4,2
2	30	800	0,8	140	16	218,3	29,10	0,85	186	4,2
2	30	800	0,8	160	16	191,0	25,46	0,85	212	4,2
2	30	800	0,8	210	16	145,5	19,40	0,85	279	4,2
2	30	800	0,8	240	16	127,3	16,98	0,85	319	4,2
2	30	800	0,8	320	16	95,5	12,73	0,85	425	4,2
2	30	800	1	120	16	318,3	42,44	0,85	159	5,3
2	30	800	1	140	16	272,8	36,38	0,85	186	5,3
2	30	800	1	160	16	238,7	31,83	0,85	212	5,3
2	30	800	1	210	16	181,9	24,25	0,85	279	5,3
2	30	800	1	240	16	159,2	21,22	0,85	319	5,3
2	30	800	1	320	16	119,4	15,92	0,85	425	5,3
2	30	800	1,6	210	16	291,0	38,80	0,85	279	8,5

Tiro	Peso funi max	Portata	Velocità cabina	Ø Puleggia	Poli	Velocità	Frequenza	Efficienza vano	Coppia	Potenza in uscita
Roping	Max Ropes Weight	Duty Load	Cabin Speed	Sheave Diameter	Poles	Speed	Frequency	Shaft Efficiency	Torque	Power Output
	[kg]	[kg]	[m/s]	[mm]		[rpm]	[Hz]		[Nm]	[kW]
2	30	800	1,6	240	16	254,6	33,95	0,85	319	8,5
2	30	800	1,6	320	16	191,0	25,46	0,85	425	8,5
2	30	1000	0,63	120	16	200,5	26,74	0,85	194	4,1
2	30	1000	0,63	140	16	171,9	22,92	0,85	226	4,1
2	30	1000	0,63	160	16	150,4	20,05	0,85	259	4,1
2	30	1000	0,63	210	16	114,6	15,28	0,85	339	4,1
2	30	1000	0,63	240	16	100,3	13,37	0,85	388	4,1
2	30	1000	0,8	120	16	254,6	33,95	0,85	194	5,2
2	30	1000	0,8	140	16	218,3	29,10	0,85	226	5,2
2	30	1000	0,8	160	16	191,0	25,46	0,85	259	5,2
2	30	1000	0,8	210	16	145,5	19,40	0,85	339	5,2
2	30	1000	0,8	240	16	127,3	16,98	0,85	388	5,2
2	30	1000	1	120	16	318,3	42,44	0,85	194	6,5
2	30	1000	1	140	16	272,8	36,38	0,85	226	6,5
2	30	1000	1	160	16	238,7	31,83	0,85	259	6,5
2	30	1000	1	210	16	181,9	24,25	0,85	339	6,5
2	30	1000	1	240	16	159,2	21,22	0,85	388	6,5
2	30	1000	1,6	210	16	291,0	38,80	0,85	339	10,3
2	30	1000	1,6	240	16	254,6	33,95	0,85	388	10,3
2	30	1250	0,63	120	16	200,5	26,74	0,85	237	5,0
2	30	1250	0,63	140	16	171,9	22,92	0,85	277	5,0
2	30	1250	0,63	160	16	150,4	20,05	0,85	316	5,0
2	30	1250	0,63	210	16	114,6	15,28	0,85	415	5,0
2	30	1250	0,8	120	16	254,6	33,95	0,85	237	6,3
2	30	1250	0,8	140	16	218,3	29,10	0,85	277	6,3
2	30	1250	0,8	160	16	191,0	25,46	0,85	316	6,3
2	30	1250	0,8	210	16	145,5	19,40	0,85	415	6,3
2	30	1250	1	120	16	318,3	42,44	0,85	237	7,9
2	30	1250	1	140	16	272,8	36,38	0,85	277	7,9
2	30	1250	1	160	16	238,7	31,83	0,85	316	7,9
2	30	1250	1	210	16	181,9	24,25	0,85	415	7,9
2	30	1250	1,6	210	16	291,0	38,80	0,85	415	12,6

Note 1

Note 2

Note 3

max 430

G-300 T1 | Note / Notes

Brake Type: DF01 - Standard 205 V DC - Other voltages on request. DFXY certified brake against Overspeed in upward direction and as UCM (EN 81-20:2020, EN 81-50:2020) with reference to Lift Directive 2014/33/EU.

Encoder Type: Absolute encoder with EnDat Interface or Incremental sin/cos, both with 2048 ppr

Duty-cycle: Max 240 sts/h - 40% ED without fans.
Max 240 sts/h - 50% ED with fans activated by thermocontacts inside motor.

Traction sheave: Traction sheave width: 120 mm. Available width 150 mm for Ø240, Ø320, Ø360 and Ø400.

Note 1: For higher ropes weight, please consult sales/technical services of Alberto Sassi SpA.

Note 2: Details on ropes/grooves provided upon lift data. Suitable for steel core ropes or also for plastic coated ropes.

Note 3: Shaft efficiency includes divertor pulleys efficiency by considering: 3 divertors for roping 2:1. Values are supposed.



G-300 T2

Tiro	Peso funi max	Portata	Velocità cabina	Ø Puleggia	Poli	Velocità	Frequenza	Efficienza vano	Coppia	Potenza in uscita
Roping	Max Ropes Weight	Duty Load	Cabin Speed	Sheave Diameter	Poles	Speed	Frequency	Shaft Efficiency	Torque	Power Output
	[kg]	[kg]	[m/s]	[mm]		[rpm]	[Hz]		[Nm]	[kW]
1	30	375	0,8	360	16	42,4	5,66	0,85	452	2,0
1	30	375	0,8	400	16	38,2	5,09	0,85	502	2,0
1	30	375	1	360	16	53,1	7,07	0,85	452	2,5
1	30	375	1	400	16	47,7	6,37	0,85	502	2,5
1	30	375	1,6	360	16	84,9	11,32	0,85	452	4,0
1	30	375	1,6	400	16	76,4	10,19	0,85	502	4,0
1	30	400	0,8	360	16	42,4	5,66	0,85	478	2,1
1	30	400	1	360	16	53,1	7,07	0,85	478	2,7
1	30	400	1,6	360	16	84,9	11,32	0,85	478	4,2
1	30	450	0,63	320	16	37,6	5,01	0,85	471	1,9
1	30	450	0,8	320	16	47,7	6,37	0,85	471	2,4
1	30	450	1	320	16	59,7	7,96	0,85	471	2,9
1	30	450	1,6	320	16	95,5	12,73	0,85	471	4,7
1	30	630	0,63	240	16	50,1	6,68	0,85	478	2,5
1	30	630	0,8	240	16	63,7	8,49	0,85	478	3,2
1	30	630	1	240	16	79,6	10,61	0,85	478	4,0
1	30	630	1,6	240	16	127,3	16,98	0,85	478	6,4
2	30	630	0,63	400	16	60,2	8,02	0,85	433	2,7
2	30	630	0,8	400	16	76,4	10,19	0,85	433	3,5
2	30	630	1	400	16	95,5	12,73	0,85	433	4,3
2	30	630	1,6	400	16	152,8	20,37	0,85	433	6,9
2	30	800	0,63	360	16	66,8	8,91	0,85	478	3,3
2	30	800	0,8	360	16	84,9	11,32	0,85	478	4,2
2	30	800	1	360	16	106,1	14,15	0,85	478	5,3
2	30	800	1,6	360	16	169,8	22,64	0,85	478	8,5
2	30	1000	0,63	320	16	75,2	10,03	0,85	517	4,1
2	30	1000	0,8	320	16	95,5	12,73	0,85	517	5,2
2	30	1000	1	320	16	119,4	15,92	0,85	517	6,5
2	30	1000	1,6	320	16	191,0	25,46	0,85	517	10,3
2	30	1250	0,63	240	16	100,3	13,37	0,85	474	5,0
2	30	1250	0,8	240	16	127,3	16,98	0,85	474	6,3
2	30	1250	1	240	16	159,2	21,22	0,85	474	7,9
2	30	1250	1,6	240	16	254,6	33,95	0,85	474	12,6

Note 1

Note 2

Note 3

max 520

G-300 T2 | Note / Notes

Brake Type: DF02 - Standard 205 V DC - Other voltages on request. DFX certified brake against Overspeed in upward direction and as UCM (EN 81-20:2020, EN 81-50:2020) with reference to Lift Directive 2014/33/EU.

Encoder Type: Absolute encoder with EnDat Interface or Incremental sin/cos, both with 2048 ppr

Duty-cycle: Max 180 sts/h - 40% ED with fans activated by thermocontacts inside motor.

Traction sheave: Traction sheave width: 120 mm. Available width 150 mm for Ø240, Ø320, Ø360 and Ø400.

Note 1: For higher ropes weight, please consult sales/technical services of Alberto Sassi SpA.

Note 2: Details on ropes/grooves provided upon lift data. Suitable for steel core ropes or also for plastic coated ropes.

Note 3: Shaft efficiency includes divertor pulleys efficiency by considering: 3 divertors for roping 2:1. Values are supposed.





Tiro / Roping 1/1 · Corsa / Travel 30 mt					
Portata Duty load [kg]	Velocità Speed [m/s]	Puleggia Sheave [mm]	Combinazione funi Ropes combination	N° funi max Max ropes nr.	Peso cabina Cabin weight [kg]
225	0,63 - 1,60	210-240	4÷6 x ø 6/6,5	8÷10 x ø 6/6,5	350 450
	0,63 - 1,60	320	3÷4 x ø 8	10 x ø 8	
	0,63 - 1,60	360	3 x ø 9	10 x ø 9	
	0,63 - 1,60	400	3 x ø 10	10 x ø 10	
320	0,63 - 1,60	210-240	5÷7 x ø 6/6,5	8÷10 x ø 6/6,5	450 550
	0,63 - 1,60	320	4÷5 x ø 8	10 x ø 8	
	0,63 - 1,60	360	3 x ø 9	10 x ø 9	
	0,63 - 1,60	400	3 x ø 10	10 x ø 10	
450	0,63 - 1,60	210 - 240	6÷8 x ø 6/6,5	8÷10 x ø 6/6,5	650 850
	0,63 - 1,60	320	4 x ø 8	10 x ø 8	
525	0,63 - 1,60	160 - 210 - 240	6÷8 x ø 6/6,5	8÷10 x ø 6/6,5	650 750
630	0,63 - 1,60	160 - 210	6÷8 x ø 6/6,5	8÷10 x ø 6/6,5	650 775
	0,63 - 1,60	240	6÷8 x ø 6/6,5	10 x ø 6/6,5	
800	0,63 - 1,60	160	8 x ø 6/6,5	8 x ø 6/6,5	600 675

Tiro / Roping 2/1 · Corsa / Travel 30 mt					
Portata Duty load [kg]	Velocità Speed [m/s]	Puleggia Sheave [mm]	Combinazione funi Ropes combination	N° funi max Max ropes nr.	Peso cabina Cabin weight [kg]
225	0,63 - 1,60	160 - 210 - 240	3÷4 ø 6/6,5	8÷10 x ø 6/6,5	400 500
	0,63 - 1,60	320	3÷4 x ø 8	10 x ø 8	
	0,63 - 1,60	360	3 x ø 9	10 x ø 9	
	0,63 - 1,60	400	3 x ø 10	10 x ø 10	
320	0,63 - 1,60	160 - 210 - 240	4÷5 ø 6/6,5	8÷10 x ø 6/6,5	500 600
	0,63 - 1,60	320	3÷4 x ø 8	10 x ø 8	
	0,63 - 1,60	360	3 x ø 9	10 x ø 9	
	0,63 - 1,60	400	3 x ø 10	10 x ø 10	
450	0,63 - 1,60	160 - 210 - 240	5÷6 x ø 6/6,5	8÷10 x ø 6/6,5	700 90
	0,63 - 1,60	320	4÷5 x ø 8	10 x ø 8	
	0,63 - 1,60	360	3÷4 x ø 9	10 x ø 9	
	0,63 - 1,60	400	3 x ø 10	10 x ø 10	
630	0,63 - 1,60	160 - 210 - 240	5÷7 x ø 6/6,5	8÷10 x ø 6/6,5	900 1100
	0,63 - 1,60	320	5÷6 x ø 8	10 x ø 8	
	0,63 - 1,60	360	4÷5 x ø 9	10 x ø 9	
	0,63 - 1,60	400	4 x ø 10	10 x ø 10	
800	0,63 - 1,60	160 - 210 - 240	6÷7 x ø 6/6,5	8÷10 x ø 6/6,5	900 1250
	0,63 - 1,60	320	5÷6 x ø 8	10 x ø 8	
	0,63 - 1,60	360	5÷6 x ø 9	10 x ø 9	
1000	0,63 - 1,60	160 - 210 - 240	7÷8 x ø 6/6,5	8÷10 x ø 6/6,5	1200 1400
	0,63 - 1,60	320	6 x ø 8	10 x ø 8	
1250	0,63 - 1,60	240	8 x ø 6/6,5	10 x ø 6/6,5	1250 1500

Altre combinazioni a richiesta. / Additional combination on request.





G-400 T1

Con o senza ventole di raffreddamento
With or without cooling fans

G-400 T2

Con o senza ventole di raffreddamento
With or without cooling fans

G-400 T3

Con ventole di raffreddamento
With cooling fans

G-400 T1

Con o senza ventole di raffreddamento / With or without cooling fans

Carico statico Static load [kg]	3500					
Coppia / Rated torque [Nm]	640					
Peso / Weight [kg]	245 (senza puleggia / without sheave)					
Portata / Duty load [kg]	480	630	630	800	1000	1250
Tiro / Roping	1/1	1/1	2/1	2/1	2/1	2/1
Gamma velocità cabina Range of cabin speed [m/s]	0,63 ÷ 2,50	0,63 ÷ 2,50	0,63 ÷ 2,50	0,63 ÷ 2,50	0,63 ÷ 2,00	0,63 ÷ 2,00
Gamma Ø pulegge Range sheave Ø [mm]	210 → 400	210 - 240 - 320	210 → 560	210 → 480	210 → 360	210 - 240 - 320
Freno / Brake	DF02					
Poli / Poles	16					

G-400 T2

Con o senza ventole di raffreddamento / With or without cooling fans

Carico statico Static load [kg]	4500					
Coppia / Rated torque [Nm]	1020					
Peso / Weight [kg]	356 (senza puleggia / without sheave)					
Portata / Duty load [kg]	630	800	1000	630 - 800 - 1000	1600	2000
Tiro / Roping	1/1	1/1	1/1	2/1	2/1	2/1
Gamma velocità cabina Range of cabin speed [m/s]	0,63 ÷ 2,50	0,63 ÷ 2,50	0,63 ÷ 2,50	0,63 ÷ 2,50	0,63 ÷ 2,00	0,63 ÷ 2,00
Gamma Ø pulegge Range sheave Ø [mm]	210 → 480	210 → 360	210 - 240 - 320	210 → 560	210 → 360	240 - 320
Freno / Brake	DQ02					
Poli / Poles	16					

G-400 T3

Con ventole di raffreddamento / With cooling fans

Carico statico Static load [kg]	5200					
Coppia / Rated torque [Nm]	1250					
Peso / Weight [kg]	364 (senza puleggia / without sheave)					
Portata / Duty load [kg]	630	1000	1250	1000	1600	2000
Tiro / Roping	1/1	1/1	1/1	2/1	2/1	2/1
Gamma velocità cabina Range of cabin speed [m/s]	0,63 ÷ 2,50	0,63 ÷ 2,50	0,63 ÷ 2,50	0,63 ÷ 2,50	0,63 ÷ 2,50	0,63 ÷ 2,50
Gamma Ø pulegge Range sheave Ø [mm]	520 - 560 - 600	320 - 360 - 400	320	600 - 650	360 → 480	320 - 360 - 400
Freno / Brake	DQ03					
Poli / Poles	16					

G-400 T1 Senza ventole di raffreddamento / Without cooling fans

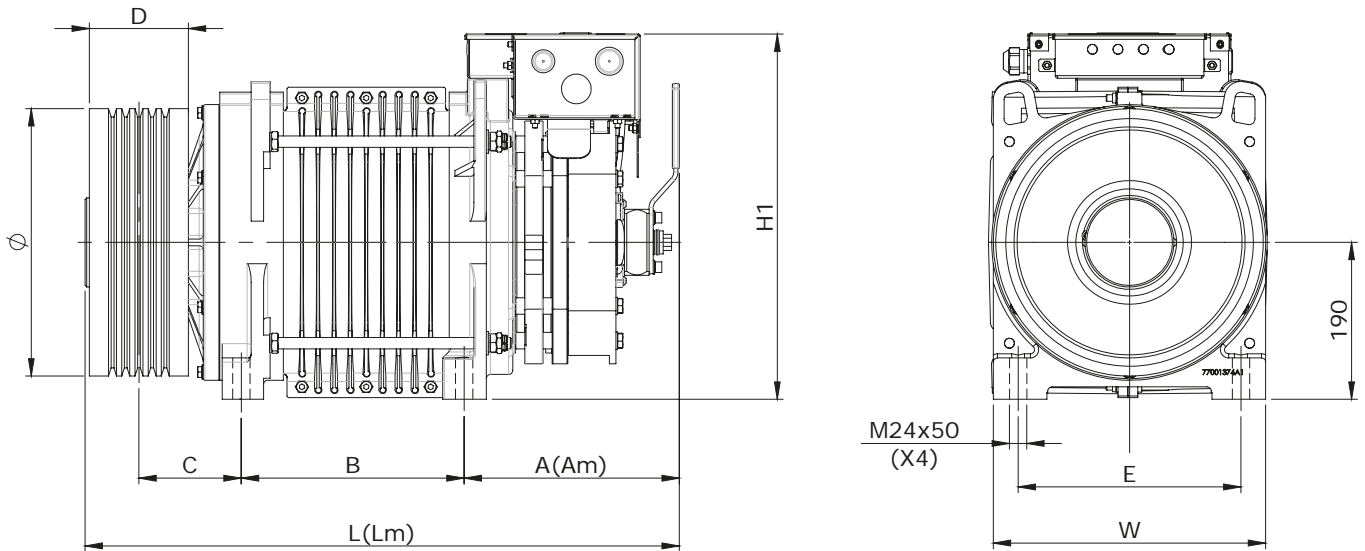

Dimensioni / Dimensions [mm]

A	L	Am*	Lm*	B	C	E	W	H1	D	Ø
215	670	260	715	270	124	270	330	445	120**	210 - 240 - 320 - 360 - 400 450 - 480 - 520 - 560 - 600
	700		745		139				150	240 - 320 - 360 - 400

* Quote con manovra apertura a mano. / Dimensions with lever for hand release.

** Ø > 400 mm: pulegge con flangia e "D" = 115 mm / Ø > 400 mm: flanged traction sheave with "D" = 115 mm

G-400 T1 Con ventole di raffreddamento / With cooling fans

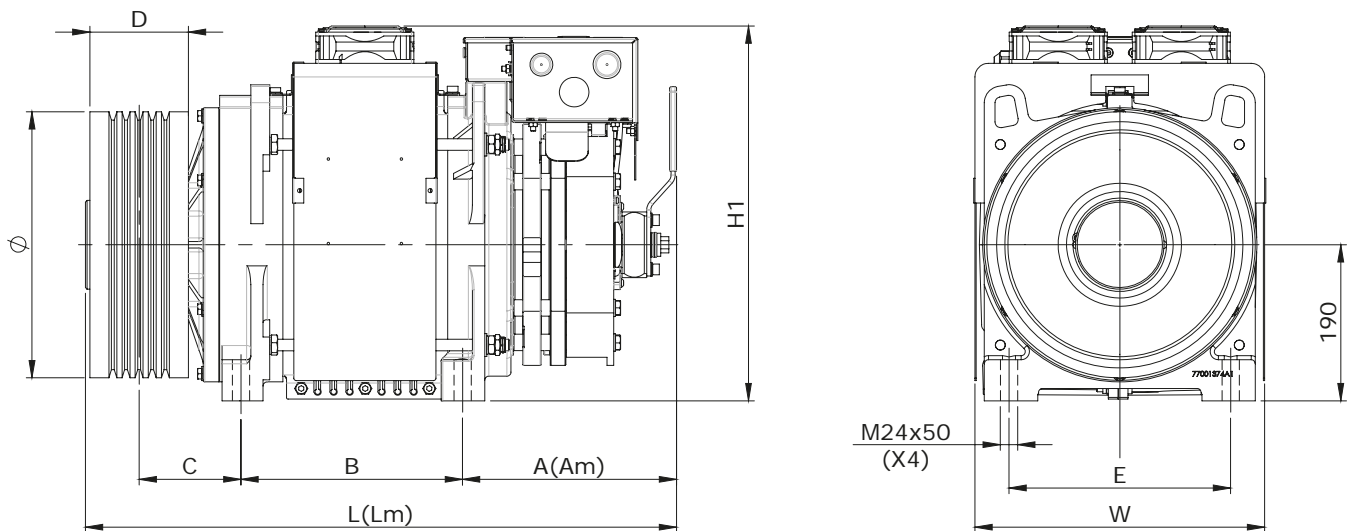

Dimensioni / Dimensions [mm]

A	L	Am*	Lm*	B	C	E	W	H1	D	Ø
215	670	260	715	270	124	270	356	456	120**	210 - 240 - 320 - 360 - 400 450 - 480 - 520 - 560 - 600
	700		745		139				150	240 - 320 - 360 - 400

* Quote con manovra apertura a mano. / Dimensions with lever for hand release.

** Ø > 400 mm: pulegge con flangia e "D" = 115 mm / Ø > 400 mm: flanged traction sheave with "D" = 115 mm

G-400 T2 Senza ventole di raffreddamento / Without cooling fans

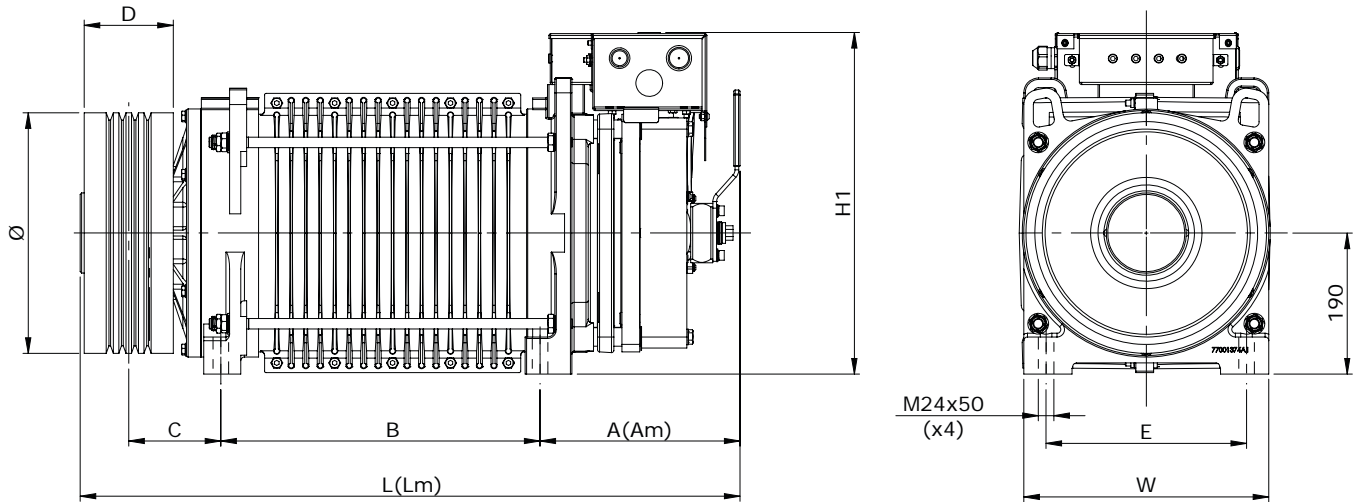

Dimensioni / Dimensions [mm]

A	L	Am*	Lm*	B	C	E	W	H1	D	Ø
225	884	270	889	430	124	270	330	460	120**	210 - 240 - 320 - 360 - 400 450 - 480 - 520 - 560 - 600
	874		919		139				150	240 - 320 - 360 - 400

* Quote con manovra apertura a mano. / Dimensions with lever for hand release.

** Ø > 400 mm: pulegge con flangia e "D" = 115 mm / Ø > 400 mm: flanged traction sheave with "D" = 115 mm

G-400 T2 Con ventole di raffreddamento / With cooling fans

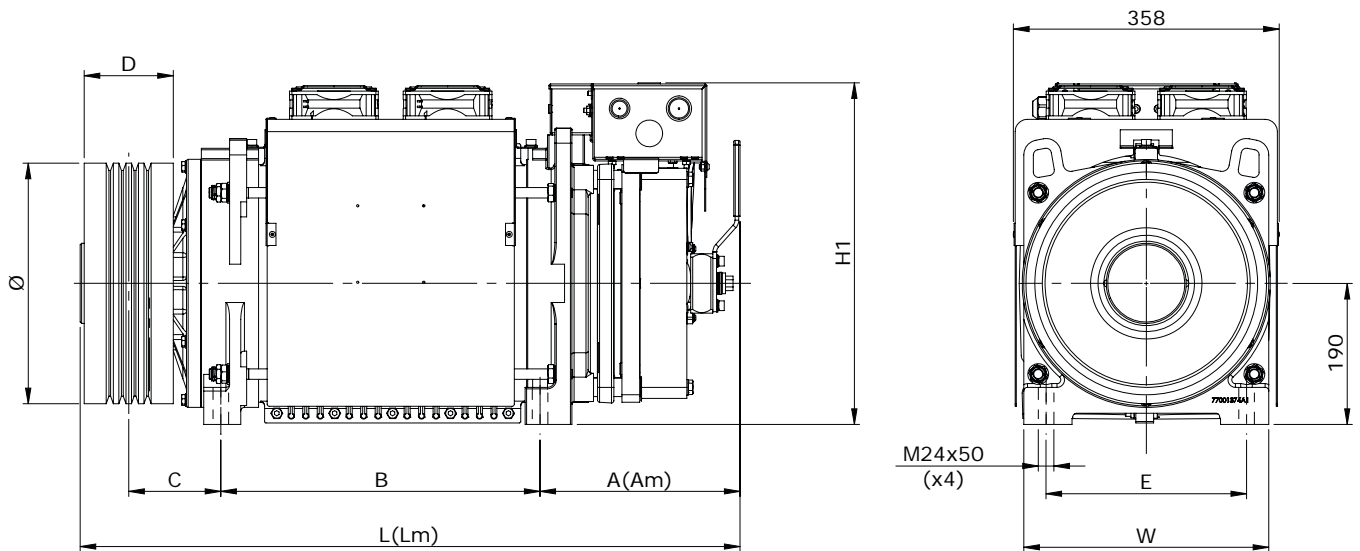

Dimensioni / Dimensions [mm]

A	L	Am*	Lm*	B	C	E	W	H1	D	Ø
225	844	270	889	430	124	270	330	460	120**	210 - 240 - 320 - 360 - 400 450 - 480 - 520 - 560 - 600
	874		919		139				150	240 - 320 - 360 - 400

* Quote con manovra apertura a mano. / Dimensions with lever for hand release.

** Ø > 400 mm: pulegge con flangia e "D" = 115 mm / Ø > 400 mm: flanged traction sheave with "D" = 115 mm

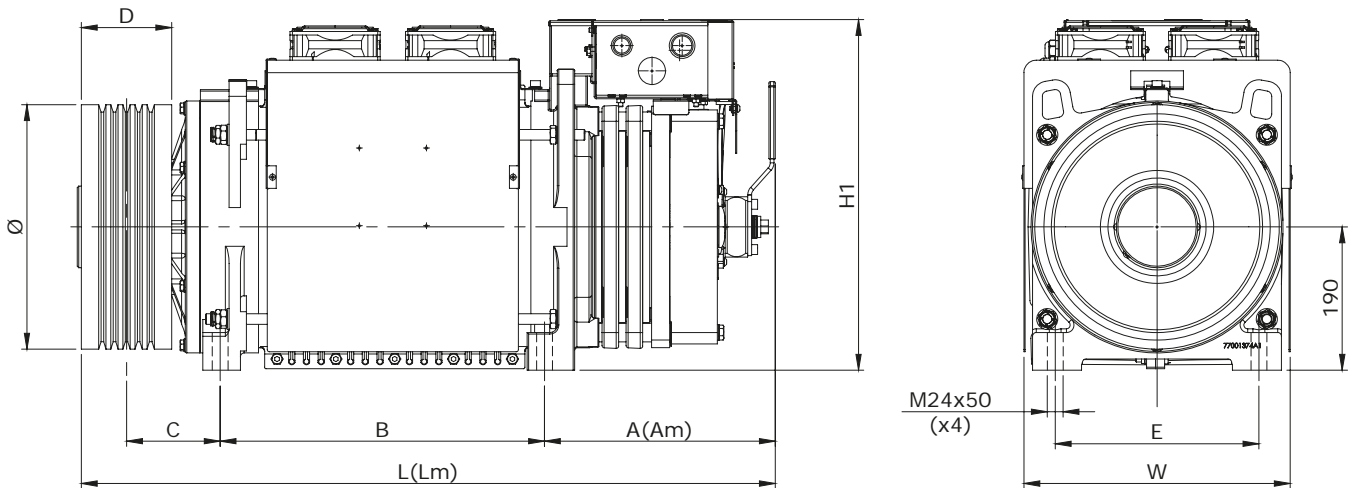

Dimensioni / Dimensions [mm]

A	L	Am*	Lm*	B	C	E	W	H1	D	Ø
279	897	324	942	430	124	270	356	465	120**	240 - 320 - 360 - 400 - 450 480 - 520 - 560 - 600 - 650
	927		972		139				150	240 - 320 - 360 - 400

* Quote con manovra apertura a mano. / Dimensions with lever for hand release.

** Ø > 400 mm: pulegge con flangia e "D" = 115 mm / Ø > 400 mm: flanged traction sheave with "D" = 115 mm

G-400 T1 IP66* Senza ventole di raffreddamento / Without cooling fans

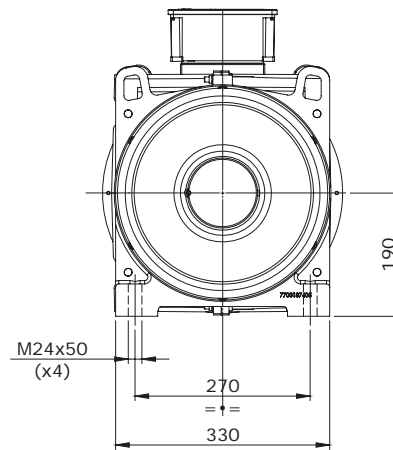
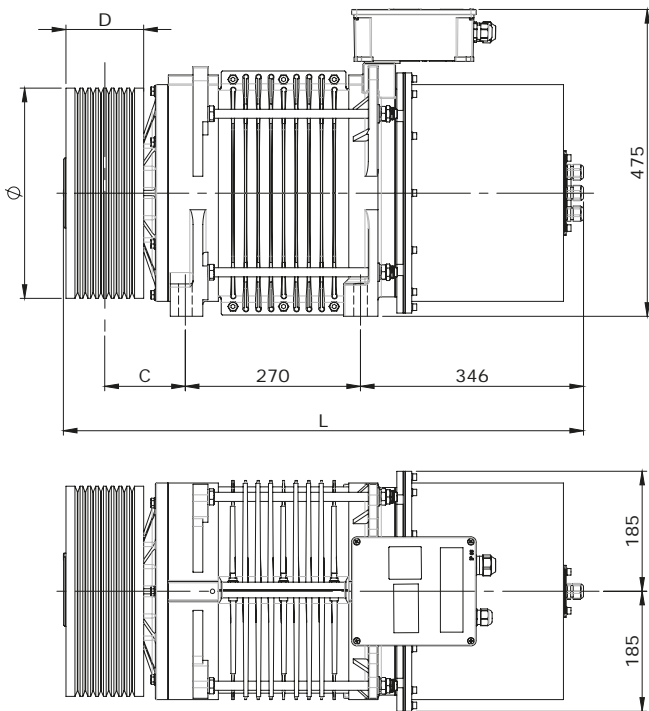

Dimensioni / Dimensions [mm]

L	C	D	Ø
800	124	120	210 - 240 - 320 - 360 - 400 450 - 480 - 520 - 560 - 600
830	139	150	240 - 320 - 360 - 400

* Configurazione solo senza ventilatore né leve del freno.
Configuration without neither fan nor brake levers.

G-400 T2 IP66* Senza ventole di raffreddamento / Without cooling fans

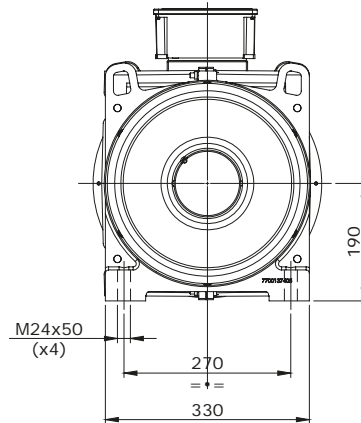
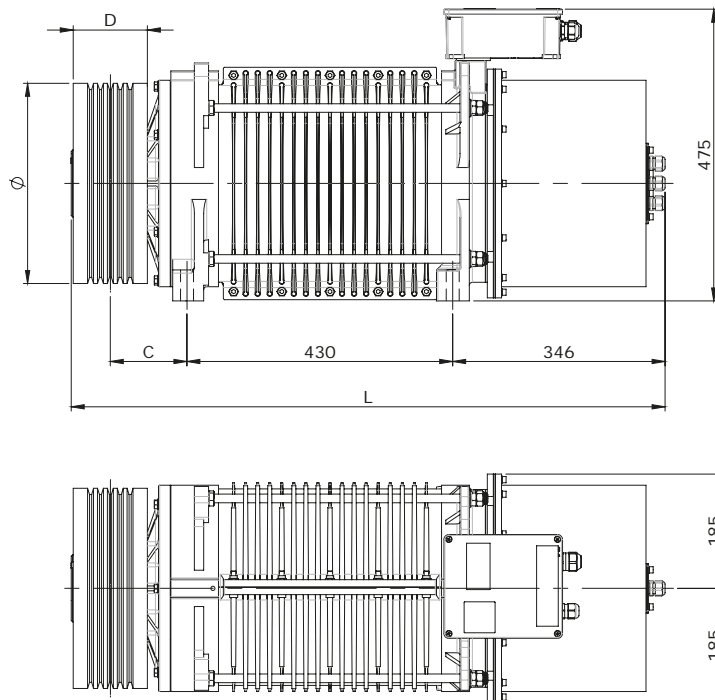

Dimensioni / Dimensions [mm]

L	C	D	Ø
960	124	120	210 - 240 - 320 - 360 - 400 450 - 480 - 520 - 560 - 600 - 650
990	139	150	240 - 320 - 360 - 400

* Configurazione solo senza ventilatore né leve del freno.
Configuration without neither fan nor brake levers.



G-400 T1* Con ventilatore speciale / With special cooling fan

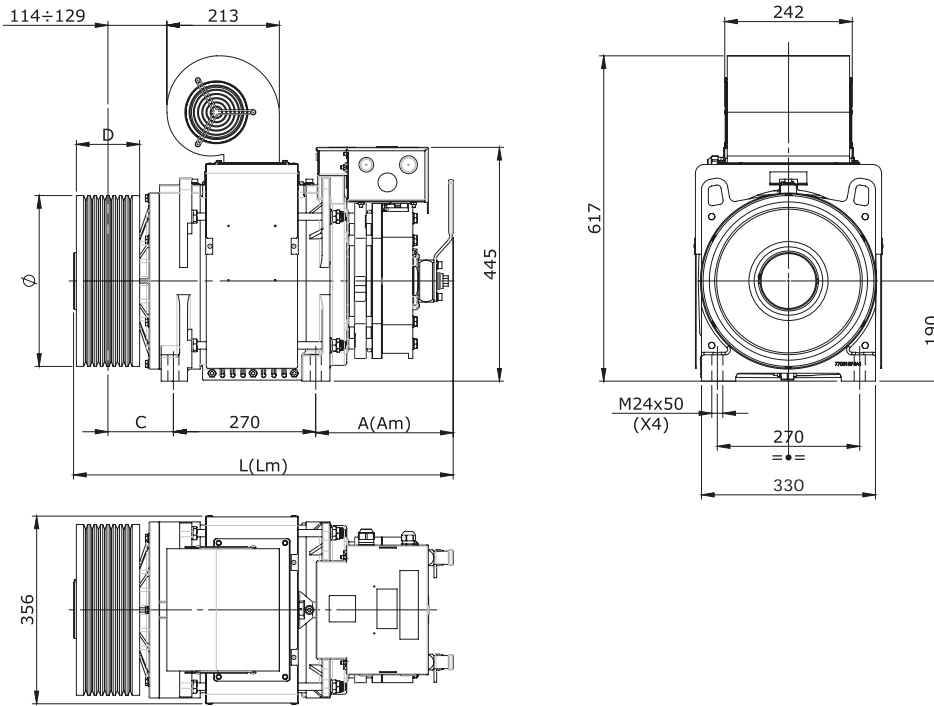

G-400 T2 · T3* Con ventilatore speciale / With special cooling fan

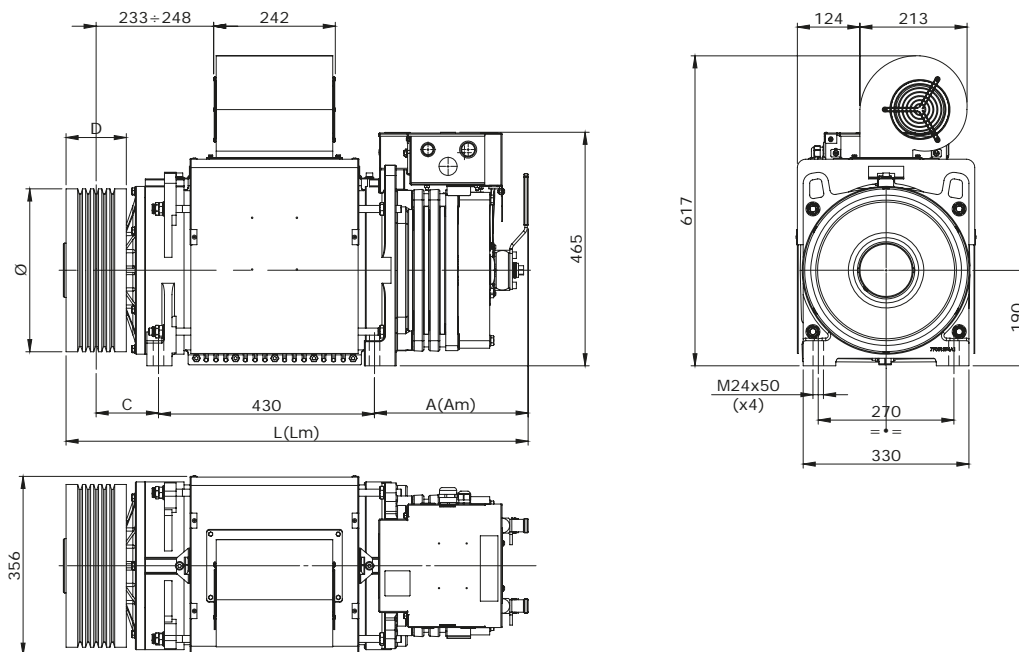

Dimensioni / Dimensions [mm]

Tipo / Type	A	L	Am**	Lm**	C	D	Ø
G400 T1	215	670	260	715	124	120	210 - 240 - 320 - 360 - 400 - 450 - 480 - 520 - 560 - 600
		700		745	139	150	240 - 320 - 360 - 400
G400 T2	247	862	292	907	124	120	210 - 240 - 320 - 360 - 400 - 450 - 480 - 520 - 560 - 600 - 650
		892		937	139	150	240 - 320 - 360 - 400
G400 T3	279	897	324	942	124	120	210 - 240 - 320 - 360 - 400 - 450 - 480 - 520 - 560 - 600 - 650
		927		972	139	150	240 - 320 - 360 - 400

* Per un maggiore ciclo di lavoro rispetto allo standard. Chiedere all'ufficio commerciale per maggiori informazioni.

For increased duty-cycle than the standard. Contact Sales dept. for further information.

** Quote con manovra apertura a mano. / Dimensions with lever for hand release.

**G-400 T1**

Tiro	Peso funi max	Portata	Velocità cabina	Ø Puleggia	Poli	Velocità	Frequenza	Efficienza vano	Coppia	Potenza in uscita
Roping	Max Ropes Weight	Duty Load	Cabin Speed	Sheave Diameter	Poles	Speed	Frequency	Shaft Efficiency	Torque	Power Output
	[kg]	[kg]	[m/s]	[mm]		[rpm]	[Hz]		[Nm]	[kW]
1	30	400	0,63	210	16	57,3	7,64	0,85	279	1,7
1	30	400	0,63	240	16	50,1	6,68	0,85	319	1,7
1	30	400	0,63	320	16	37,6	5,01	0,85	425	1,7
1	30	400	0,63	360	16	33,4	4,46	0,85	478	1,7
1	30	400	0,63	400	16	30,1	4,01	0,85	531	1,7
1	30	400	0,63	450	16	26,7	3,57	0,85	597	1,7
1	30	400	0,63	480	16	25,1	3,34	0,85	637	1,7
1	30	400	1	210	16	90,9	12,13	0,85	279	2,7
1	30	400	1	240	16	79,6	10,61	0,85	319	2,7
1	30	400	1	320	16	59,7	7,96	0,85	425	2,7
1	30	400	1	360	16	53,1	7,07	0,85	478	2,7
1	30	400	1	400	16	47,7	6,37	0,85	531	2,7
1	30	400	1	450	16	42,4	5,66	0,85	597	2,7
1	30	400	1	480	16	39,8	5,31	0,85	637	2,7
1	30	400	1,6	210	16	145,5	19,40	0,85	279	4,2
1	30	400	1,6	240	16	127,3	16,98	0,85	319	4,2
1	30	400	1,6	320	16	95,5	12,73	0,85	425	4,2
1	30	400	1,6	360	16	84,9	11,32	0,85	478	4,2
1	30	400	1,6	400	16	76,4	10,19	0,85	531	4,2
1	30	400	1,6	450	16	67,9	9,05	0,85	597	4,2
1	30	400	1,6	480	16	63,7	8,49	0,85	637	4,2
1	30	400	2,5	210	16	227,4	30,32	0,85	279	6,6
1	30	400	2,5	240	16	198,9	26,53	0,85	319	6,6
1	30	400	2,5	320	16	149,2	19,89	0,85	425	6,6
1	30	400	2,5	360	16	132,6	17,68	0,85	478	6,6
1	30	400	2,5	400	16	119,4	15,92	0,85	531	6,6
1	30	400	2,5	450	16	106,1	14,15	0,85	597	6,6
1	30	400	2,5	480	16	99,5	13,26	0,85	637	6,6
1	30	480	0,63	210	16	57,3	7,64	0,85	327	2,0
1	30	480	0,63	240	16	50,1	6,68	0,85	374	2,0
1	30	480	0,63	320	16	37,6	5,01	0,85	499	2,0
1	30	480	0,63	360	16	33,4	4,46	0,85	561	2,0
1	30	480	0,63	400	16	30,1	4,01	0,85	623	2,0
1	30	480	1	210	16	90,9	12,13	0,85	327	3,1
1	30	480	1	240	16	79,6	10,61	0,85	374	3,1
1	30	480	1	320	16	59,7	7,96	0,85	499	3,1
1	30	480	1	360	16	53,1	7,07	0,85	561	3,1
1	30	480	1	400	16	47,7	6,37	0,85	623	3,1
1	30	480	1,6	210	16	145,5	19,40	0,85	327	5,0
1	30	480	1,6	240	16	127,3	16,98	0,85	374	5,0
1	30	480	1,6	320	16	95,5	12,73	0,85	499	5,0
1	30	480	1,6	360	16	84,9	11,32	0,85	561	5,0



Tiro	Peso funi max	Portata	Velocità cabina	Ø Puleggia	Poli	Velocità	Frequenza	Efficienza vano	Coppia	Potenza in uscita
Roping	Max Ropes Weight	Duty Load	Cabin Speed	Sheave Diameter	Poles	Speed	Frequency	Shaft Efficiency	Torque	Power Output
	[kg]	[kg]	[m/s]	[mm]		[rpm]	[Hz]		[Nm]	[kW]
1	30	480	1,6	400	16	76,4	10,19	0,85	623	5,0
1	30	480	2,5	210	16	227,4	30,32	0,85	327	7,8
1	30	480	2,5	240	16	198,9	26,53	0,85	374	7,8
1	30	480	2,5	320	16	149,2	19,89	0,85	499	7,8
1	30	480	2,5	360	16	132,6	17,68	0,85	561	7,8
1	30	480	2,5	400	16	119,4	15,92	0,85	623	7,8
1	30	630	0,63	210	16	57,3	7,64	0,85	418	2,5
1	30	630	0,63	240	16	50,1	6,68	0,85	478	2,5
1	30	630	0,63	320	16	37,6	5,01	0,85	637	2,5
1	30	630	1	210	16	90,9	12,13	0,85	418	4,0
1	30	630	1	240	16	79,6	10,61	0,85	478	4,0
1	30	630	1	320	16	59,7	7,96	0,85	637	4,0
1	30	630	1,6	210	16	145,5	19,40	0,85	418	6,4
1	30	630	1,6	240	16	127,3	16,98	0,85	478	6,4
1	30	630	1,6	320	16	95,5	12,73	0,85	637	6,4
1	30	630	2,5	210	16	227,4	30,32	0,85	418	10,0
1	30	630	2,5	240	16	198,9	26,53	0,85	478	10,0
1	30	630	2,5	320	16	149,2	19,89	0,85	637	10,0
1	30	750	0,63	210	16	57,3	7,64	0,85	491	2,9
1	30	750	0,63	240	16	50,1	6,68	0,85	561	2,9
1	30	750	1	210	16	90,9	12,13	0,85	491	4,7
1	30	750	1	240	16	79,6	10,61	0,85	561	4,7
1	30	750	1,6	210	16	145,5	19,40	0,85	491	7,5
1	30	750	1,6	240	16	127,3	16,98	0,85	561	7,5
1	30	750	2,5	210	16	227,4	30,32	0,85	491	11,7
1	30	750	2,5	240	16	198,9	26,53	0,85	561	11,7
1	30	800	0,63	240	16	50,1	6,68	0,85	596	3,1
1	30	800	1	240	16	79,6	10,61	0,85	596	5,0
1	30	800	1,6	240	16	127,3	16,98	0,85	596	7,9
1	30	800	2,5	240	16	198,9	26,53	0,85	596	12,4
2	30	480	0,63	210	16	114,6	15,28	0,85	182	2,2
2	30	480	0,63	240	16	100,3	13,37	0,85	208	2,2
2	30	480	0,63	320	16	75,2	10,03	0,85	277	2,2
2	30	480	0,63	360	16	66,8	8,91	0,85	312	2,2
2	30	480	0,63	400	16	60,2	8,02	0,85	346	2,2
2	30	480	0,63	450	16	53,5	7,13	0,85	390	2,2
2	30	480	0,63	480	16	50,1	6,68	0,85	415	2,2
2	30	480	0,63	520	16	46,3	6,17	0,85	450	2,2
2	30	480	0,63	560	16	43,0	5,73	0,85	485	2,2
2	30	480	0,63	600	16	40,1	5,35	0,85	519	2,2
2	30	480	1	210	16	181,9	24,25	0,85	182	3,5
2	30	480	1	240	16	159,2	21,22	0,85	208	3,5
2	30	480	1	320	16	119,4	15,92	0,85	277	3,5
2	30	480	1	360	16	106,1	14,15	0,85	312	3,5
2	30	480	1	400	16	95,5	12,73	0,85	346	3,5

Tiro	Peso funi max	Portata	Velocità cabina	Ø Puleggia	Poli	Velocità	Frequenza	Efficienza vano	Coppia	Potenza in uscita
Roping	Max Ropes Weight	Duty Load	Cabin Speed	Sheave Diameter	Poles	Speed	Frequency	Shaft Efficiency	Torque	Power Output
	[kg]	[kg]	[m/s]	[mm]		[rpm]	[Hz]		[Nm]	[kW]
2	30	480	1	450	16	84,9	11,32	0,85	390	3,5
2	30	480	1	480	16	79,6	10,61	0,85	415	3,5
2	30	480	1	520	16	73,5	9,79	0,85	450	3,5
2	30	480	1	560	16	68,2	9,09	0,85	485	3,5
2	30	480	1	600	16	63,7	8,49	0,85	519	3,5
2	30	480	1,6	210	16	291,0	38,80	0,85	182	5,5
2	30	480	1,6	240	16	254,6	33,95	0,85	208	5,5
2	30	480	1,6	320	16	191,0	25,46	0,85	277	5,5
2	30	480	1,6	360	16	169,8	22,64	0,85	312	5,5
2	30	480	1,6	400	16	152,8	20,37	0,85	346	5,5
2	30	480	1,6	450	16	135,8	18,11	0,85	390	5,5
2	30	480	1,6	480	16	127,3	16,98	0,85	415	5,5
2	30	480	1,6	520	16	117,5	15,67	0,85	450	5,5
2	30	480	1,6	560	16	109,1	14,55	0,85	485	5,5
2	30	480	1,6	600	16	101,9	13,58	0,85	519	5,5
2	30	480	2,5	320	16	298,4	39,79	0,85	277	8,7
2	30	480	2,5	360	16	265,3	35,37	0,85	312	8,7
2	30	480	2,5	400	16	238,7	31,83	0,85	346	8,7
2	30	480	2,5	450	16	212,2	28,29	0,85	390	8,7
2	30	480	2,5	480	16	198,9	26,53	0,85	415	8,7
2	30	480	2,5	520	16	183,6	24,49	0,85	450	8,7
2	30	480	2,5	560	16	170,5	22,74	0,85	485	8,7
2	30	480	2,5	600	16	159,2	21,22	0,85	519	8,7
2	30	630	0,63	210	16	114,6	15,28	0,85	227	2,7
2	30	630	0,63	240	16	100,3	13,37	0,85	260	2,7
2	30	630	0,63	320	16	75,2	10,03	0,85	346	2,7
2	30	630	0,63	360	16	66,8	8,91	0,85	390	2,7
2	30	630	0,63	400	16	60,2	8,02	0,85	433	2,7
2	30	630	0,63	450	16	53,5	7,13	0,85	487	2,7
2	30	630	0,63	480	16	50,1	6,68	0,85	519	2,7
2	30	630	0,63	520	16	46,3	6,17	0,85	563	2,7
2	30	630	0,63	560	16	43,0	5,73	0,85	606	2,7
2	30	630	1	210	16	181,9	24,25	0,85	227	4,3
2	30	630	1	240	16	159,2	21,22	0,85	260	4,3
2	30	630	1	320	16	119,4	15,92	0,85	346	4,3
2	30	630	1	360	16	106,1	14,15	0,85	390	4,3
2	30	630	1	400	16	95,5	12,73	0,85	433	4,3
2	30	630	1	450	16	84,9	11,32	0,85	487	4,3
2	30	630	1	480	16	79,6	10,61	0,85	519	4,3
2	30	630	1	520	16	73,5	9,79	0,85	563	4,3
2	30	630	1	560	16	68,2	9,09	0,85	606	4,3
2	30	630	1,6	210	16	291,0	38,80	0,85	227	6,9
2	30	630	1,6	240	16	254,6	33,95	0,85	260	6,9
2	30	630	1,6	320	16	191,0	25,46	0,85	346	6,9
2	30	630	1,6	360	16	169,8	22,64	0,85	390	6,9

Tiro	Peso funi max	Portata	Velocità cabina	Ø Puleggia	Poli	Velocità	Frequenza	Efficienza vano	Coppia	Potenza in uscita
Roping	Max Ropes Weight	Duty Load	Cabin Speed	Sheave Diameter	Poles	Speed	Frequency	Shaft Efficiency	Torque	Power Output
	[kg]	[kg]	[m/s]	[mm]		[rpm]	[Hz]		[Nm]	[kW]
2	30	630	1,6	400	16	152,8	20,37	0,85	433	6,9
2	30	630	1,6	450	16	135,8	18,11	0,85	487	6,9
2	30	630	1,6	480	16	127,3	16,98	0,85	519	6,9
2	30	630	1,6	520	16	117,5	15,67	0,85	563	6,9
2	30	630	1,6	560	16	109,1	14,55	0,85	606	6,9
2	30	630	2,5	320	16	298,4	39,79	0,85	346	10,8
2	30	630	2,5	360	16	265,3	35,37	0,85	390	10,8
2	30	630	2,5	400	16	238,7	31,83	0,85	433	10,8
2	30	630	2,5	450	16	212,2	28,29	0,85	487	10,8
2	30	630	2,5	480	16	198,9	26,53	0,85	519	10,8
2	30	630	2,5	520	16	183,6	24,49	0,85	563	10,8
2	30	630	2,5	560	16	170,5	22,74	0,85	606	10,8
2	30	800	0,63	210	16	114,6	15,28	0,85	279	3,3
2	30	800	0,63	240	16	100,3	13,37	0,85	319	3,3
2	30	800	0,63	320	16	75,2	10,03	0,85	425	3,3
2	30	800	0,63	360	16	66,8	8,91	0,85	478	3,3
2	30	800	0,63	400	16	60,2	8,02	0,85	531	3,3
2	30	800	0,63	450	16	53,5	7,13	0,85	597	3,3
2	30	800	0,63	480	16	50,1	6,68	0,85	637	3,3
2	30	800	1	210	16	181,9	24,25	0,85	279	5,3
2	30	800	1	240	16	159,2	21,22	0,85	319	5,3
2	30	800	1	320	16	119,4	15,92	0,85	425	5,3
2	30	800	1	360	16	106,1	14,15	0,85	478	5,3
2	30	800	1	400	16	95,5	12,73	0,85	531	5,3
2	30	800	1	450	16	84,9	11,32	0,85	597	5,3
2	30	800	1	480	16	79,6	10,61	0,85	637	5,3
2	30	800	1,6	210	16	291,0	38,80	0,85	279	8,5
2	30	800	1,6	240	16	254,6	33,95	0,85	319	8,5
2	30	800	1,6	320	16	191,0	25,46	0,85	425	8,5
2	30	800	1,6	360	16	169,8	22,64	0,85	478	8,5
2	30	800	1,6	400	16	152,8	20,37	0,85	531	8,5
2	30	800	1,6	450	16	135,8	18,11	0,85	597	8,5
2	30	800	1,6	480	16	127,3	16,98	0,85	637	8,5
2	30	800	2,5	320	16	298,4	39,79	0,85	425	13,3
2	30	800	2,5	360	16	265,3	35,37	0,85	478	13,3
2	30	800	2,5	400	16	238,7	31,83	0,85	531	13,3
2	30	800	2,5	450	16	212,2	28,29	0,85	597	13,3
2	30	800	2,5	480	16	198,9	26,53	0,85	637	13,3
2	30	1000	0,63	210	16	114,6	15,28	0,85	339	4,1
2	30	1000	0,63	240	16	100,3	13,37	0,85	388	4,1
2	30	1000	0,63	320	16	75,2	10,03	0,85	517	4,1
2	30	1000	0,63	360	16	66,8	8,91	0,85	582	4,1
2	30	1000	1	210	16	181,9	24,25	0,85	339	6,5
2	30	1000	1	240	16	159,2	21,22	0,85	388	6,5
2	30	1000	1	320	16	119,4	15,92	0,85	517	6,5

Tiro	Peso funi max	Portata	Velocità cabina	Ø Puleggia	Poli	Velocità	Frequenza	Efficienza vano	Coppia	Potenza in uscita
Roping	Max Ropes Weight	Duty Load	Cabin Speed	Sheave Diameter	Poles	Speed	Frequency	Shaft Efficiency	Torque	Power Output
	[kg]	[kg]	[m/s]	[mm]		[rpm]	[Hz]		[Nm]	[kW]
2	30	1000	1	360	16	106,1	14,15	0,85	582	6,5
2	30	1000	1,6	210	16	291,0	38,80	0,85	339	10,3
2	30	1000	1,6	240	16	254,6	33,95	0,85	388	10,3
2	30	1000	1,6	320	16	191,0	25,46	0,85	517	10,3
2	30	1000	1,6	360	16	169,8	22,64	0,85	582	10,3
2	30	1000	2,5	320	16	298,4	39,79	0,85	517	16,2
2	30	1000	2,5	360	16	265,3	35,37	0,85	582	16,2
2	30	1125	0,63	210	16	114,6	15,28	0,85	377	4,5
2	30	1125	0,63	240	16	100,3	13,37	0,85	431	4,5
2	30	1125	0,63	320	16	75,2	10,03	0,85	575	4,5
2	30	1125	1	210	16	181,9	24,25	0,85	377	7,2
2	30	1125	1	240	16	159,2	21,22	0,85	431	7,2
2	30	1125	1	320	16	119,4	15,92	0,85	575	7,2
2	30	1125	1,6	210	16	291,0	38,80	0,85	377	11,5
2	30	1125	1,6	240	16	254,6	33,95	0,85	431	11,5
2	30	1125	1,6	320	16	191,0	25,46	0,85	575	11,5
2	30	1125	2	240	16	318,3	42,44	0,85	431	14,4
2	30	1125	2	320	16	238,7	31,83	0,85	575	14,4
2	30	1125	2,5	320	16	298,4	39,79	0,85	575	18,0
2	30	1250	0,63	210	16	114,6	15,28	0,85	415	5,0
2	30	1250	0,63	240	16	100,3	13,37	0,85	474	5,0
2	30	1250	0,63	320	16	75,2	10,03	0,85	632	5,0
2	30	1250	1	210	16	181,9	24,25	0,85	415	7,9
2	30	1250	1	240	16	159,2	21,22	0,85	474	7,9
2	30	1250	1	320	16	119,4	15,92	0,85	632	7,9
2	30	1250	1,6	210	16	291,0	38,80	0,85	415	12,6
2	30	1250	1,6	240	16	254,6	33,95	0,85	474	12,6
2	30	1250	1,6	320	16	191,0	25,46	0,85	632	12,6
2	30	1250	2	240	16	318,3	42,44	0,85	474	15,8
2	30	1250	2	320	16	238,7	31,83	0,85	632	15,8
2	30	1250	2,5	320	16	298,4	39,79	0,85	632	19,8

Note 1

Note 2

Note 3

Note 4

max 640

G-400 T1 | Note / Notes

Brake Type: DF02 - Standard 205 V DC - Other voltages on request. DFX certified brake against Overspeed in upward direction and as UCM (EN 81-20:2020, EN 81-50:2020) with reference to Lift Directive 2014/33/EU.

Encoder Type: Absolute encoder with EnDat Interface or Incremental sin/cos, both with 2048 ppr

Duty-cycle: Max 240 sts/h - 40% ED without fans.
Max 240 sts/h - 50% ED with fans activated by thermocontacts inside motor.

Traction sheave: Traction sheave length: 120 mm. Available length 150 mm for Ø240, Ø320, Ø360 and Ø400.

Note 1: For higher ropes weight, please consult sales/technical services of Alberto Sassi SpA.

Note 2: Details on ropes/grooves provided upon lift data. Suitable for steel core ropes or also for plastic coated ropes.

Note 3: For frequencies lower than 5 Hz, please consult your inverter supplier.

Note 4: Shaft efficiency includes divertor pulleys efficiency by considering: 3 divertors for roping 2:1. Values are supposed.

G-400 T2

Tiro	Peso funi max	Portata	Velocità cabina	Ø Puleggia	Poli	Velocità	Frequenza	Efficienza vano	Coppia	Potenza in uscita
Roping	Max Ropes Weight	Duty Load	Cabin Speed	Sheave Diameter	Poles	Speed	Frequency	Shaft Efficiency	Torque	Power Output
	[kg]	[kg]	[m/s]	[mm]		[rpm]	[Hz]		[Nm]	[kW]
1	50	480	0,63	450	16	26,7	3,57	0,85	753	2,1
1	50	480	0,63	480	16	25,1	3,34	0,85	803	2,1
1	50	480	0,63	520	16	23,1	3,09	0,85	870	2,1
1	50	480	0,63	560	16	21,5	2,86	0,85	937	2,1
1	50	480	0,63	600	16	20,1	2,67	0,85	1004	2,1
1	50	480	1	450	16	42,4	5,66	0,85	753	3,3
1	50	480	1	480	16	39,8	5,31	0,85	803	3,3
1	50	480	1	520	16	36,7	4,90	0,85	870	3,3
1	50	480	1	560	16	34,1	4,55	0,85	937	3,3
1	50	480	1	600	16	31,8	4,24	0,85	1004	3,3
1	50	480	1,6	450	16	67,9	9,05	0,85	753	5,4
1	50	480	1,6	480	16	63,7	8,49	0,85	803	5,4
1	50	480	1,6	520	16	58,8	7,84	0,85	870	5,4
1	50	480	1,6	560	16	54,6	7,28	0,85	937	5,4
1	50	480	1,6	600	16	50,9	6,79	0,85	1004	5,4
1	50	480	2,5	450	16	106,1	14,15	0,85	753	8,4
1	50	480	2,5	480	16	99,5	13,26	0,85	803	8,4
1	50	480	2,5	520	16	91,8	12,24	0,85	870	8,4
1	50	480	2,5	560	16	85,3	11,37	0,85	937	8,4
1	50	480	2,5	600	16	79,6	10,61	0,85	1004	8,4
1	50	630	0,63	360	16	33,4	4,46	0,85	758	2,7
1	50	630	0,63	400	16	30,1	4,01	0,85	843	2,7
1	50	630	0,63	450	16	26,7	3,57	0,85	948	2,7
1	50	630	0,63	480	16	25,1	3,34	0,85	1011	2,7
1	50	630	1	360	16	53,1	7,07	0,85	758	4,2
1	50	630	1	400	16	47,7	6,37	0,85	843	4,2
1	50	630	1	450	16	42,4	5,66	0,85	948	4,2
1	50	630	1	480	16	39,8	5,31	0,85	1011	4,2
1	50	630	1,6	360	16	84,9	11,32	0,85	758	6,7
1	50	630	1,6	400	16	76,4	10,19	0,85	843	6,7
1	50	630	1,6	450	16	67,9	9,05	0,85	948	6,7
1	50	630	1,6	480	16	63,7	8,49	0,85	1011	6,7
1	50	630	2,5	360	16	132,6	17,68	0,85	758	10,5
1	50	630	2,5	400	16	119,4	15,92	0,85	843	10,5
1	50	630	2,5	450	16	106,1	14,15	0,85	948	10,5
1	50	630	2,5	480	16	99,5	13,26	0,85	1011	10,5
1	50	800	0,63	320	16	37,6	5,01	0,85	831	3,3
1	50	800	0,63	360	16	33,4	4,46	0,85	935	3,3
1	50	800	1	320	16	59,7	7,96	0,85	831	5,2
1	50	800	1	360	16	53,1	7,07	0,85	935	5,2
1	50	800	1,6	320	16	95,5	12,73	0,85	831	8,3
1	50	800	1,6	360	16	84,9	11,32	0,85	935	8,3
1	50	800	2,5	320	16	149,2	19,89	0,85	831	13,0
1	50	800	2,5	360	16	132,6	17,68	0,85	935	13,0
1	50	1000	0,63	210	16	57,3	7,64	0,85	667	4,0
1	50	1000	0,63	240	16	50,1	6,68	0,85	762	4,0
1	50	1000	0,63	320	16	37,6	5,01	0,85	1016	4,0
1	50	1000	1	210	16	90,9	12,13	0,85	667	6,3

Tiro	Peso funi max	Portata	Velocità cabina	Ø Puleggia	Poli	Velocità	Frequenza	Efficienza vano	Coppia	Potenza in uscita
Roping	Max Ropes Weight	Duty Load	Cabin Speed	Sheave Diameter	Poles	Speed	Frequency	Shaft Efficiency	Torque	Power Output
	[kg]	[kg]	[m/s]	[mm]		[rpm]	[Hz]		[Nm]	[kW]
1	50	1000	1	240	16	79,6	10,61	0,85	762	6,3
1	50	1000	1	320	16	59,7	7,96	0,85	1016	6,3
1	50	1000	1,6	210	16	145,5	19,40	0,85	667	10,2
1	50	1000	1,6	240	16	127,3	16,98	0,85	762	10,2
1	50	1000	1,6	320	16	95,5	12,73	0,85	1016	10,2
1	50	1000	2,5	210	16	227,4	30,32	0,85	667	15,9
1	50	1000	2,5	240	16	198,9	26,53	0,85	762	15,9
1	50	1000	2,5	320	16	149,2	19,89	0,85	1016	15,9
2	50	1000	0,63	400	16	60,2	8,02	0,85	692	4,4
2	50	1000	0,63	450	16	53,5	7,13	0,85	779	4,4
2	50	1000	0,63	480	16	50,1	6,68	0,85	831	4,4
2	50	1000	0,63	520	16	46,3	6,17	0,85	900	4,4
2	50	1000	0,63	560	16	43,0	5,73	0,85	969	4,4
2	50	1000	1	400	16	95,5	12,73	0,85	692	6,9
2	50	1000	1	450	16	84,9	11,32	0,85	779	6,9
2	50	1000	1	480	16	79,6	10,61	0,85	831	6,9
2	50	1000	1	520	16	73,5	9,79	0,85	900	6,9
2	50	1000	1	560	16	68,2	9,09	0,85	969	6,9
2	50	1000	1,6	400	16	152,8	20,37	0,85	692	11,1
2	50	1000	1,6	450	16	135,8	18,11	0,85	779	11,1
2	50	1000	1,6	480	16	127,3	16,98	0,85	831	11,1
2	50	1000	1,6	520	16	117,5	15,67	0,85	900	11,1
2	50	1000	1,6	560	16	109,1	14,55	0,85	969	11,1
2	50	1000	2,5	400	16	238,7	31,83	0,85	692	17,3
2	50	1000	2,5	450	16	212,2	28,29	0,85	779	17,3
2	50	1000	2,5	480	16	198,9	26,53	0,85	831	17,3
2	50	1000	2,5	520	16	183,6	24,49	0,85	900	17,3
2	50	1000	2,5	560	16	170,5	22,74	0,85	969	17,3
2	50	1250	0,63	210	16	114,6	15,28	0,85	439	5,3
2	50	1250	0,63	240	16	100,3	13,37	0,85	502	5,3
2	50	1250	0,63	320	16	75,2	10,03	0,85	669	5,3
2	50	1250	0,63	360	16	66,8	8,91	0,85	753	5,3
2	50	1250	0,63	400	16	60,2	8,02	0,85	837	5,3
2	50	1250	0,63	450	16	53,5	7,13	0,85	941	5,3
2	50	1250	0,63	480	16	50,1	6,68	0,85	1004	5,3
2	50	1250	1	210	16	181,9	24,25	0,85	439	8,4
2	50	1250	1	240	16	159,2	21,22	0,85	502	8,4
2	50	1250	1	320	16	119,4	15,92	0,85	669	8,4
2	50	1250	1	360	16	106,1	14,15	0,85	753	8,4
2	50	1250	1	400	16	95,5	12,73	0,85	837	8,4
2	50	1250	1	450	16	84,9	11,32	0,85	941	8,4
2	50	1250	1	480	16	79,6	10,61	0,85	1004	8,4
2	50	1250	1,6	210	16	291,0	38,80	0,85	439	13,4
2	50	1250	1,6	240	16	254,6	33,95	0,85	502	13,4
2	50	1250	1,6	320	16	191,0	25,46	0,85	669	13,4
2	50	1250	1,6	360	16	169,8	22,64	0,85	753	13,4
2	50	1250	1,6	400	16	152,8	20,37	0,85	837	13,4
2	50	1250	1,6	450	16	135,8	18,11	0,85	941	13,4
2	50	1250	1,6	480	16	127,3	16,98	0,85	1004	13,4

Tiro	Peso funi max	Portata	Velocità cabina	Ø Puleggia	Poli	Velocità	Frequenza	Efficienza vano	Coppia	Potenza in uscita
Roping	Max Ropes Weight	Duty Load	Cabin Speed	Sheave Diameter	Poles	Speed	Frequency	Shaft Efficiency	Torque	Power Output
	[kg]	[kg]	[m/s]	[mm]		[rpm]	[Hz]		[Nm]	[kW]
2	50	1250	2,5	320	16	298,4	39,79	0,85	669	20,9
2	50	1250	2,5	360	16	265,3	35,37	0,85	753	20,9
2	50	1250	2,5	400	16	238,7	31,83	0,85	837	20,9
2	50	1250	2,5	450	16	212,2	28,29	0,85	941	20,9
2	50	1250	2,5	480	16	198,9	26,53	0,85	1004	20,9
2	50	1600	0,63	210	16	114,6	15,28	0,85	545	6,5
2	50	1600	0,63	240	16	100,3	13,37	0,85	623	6,5
2	50	1600	0,63	320	16	75,2	10,03	0,85	831	6,5
2	50	1600	0,63	360	16	66,8	8,91	0,85	935	6,5
2	50	1600	1	210	16	181,9	24,25	0,85	545	10,4
2	50	1600	1	240	16	159,2	21,22	0,85	623	10,4
2	50	1600	1	320	16	119,4	15,92	0,85	831	10,4
2	50	1600	1	360	16	106,1	14,15	0,85	935	10,4
2	50	1600	1,6	210	16	291,0	38,80	0,85	545	16,6
2	50	1600	1,6	240	16	254,6	33,95	0,85	623	16,6
2	50	1600	1,6	320	16	191,0	25,46	0,85	831	16,6
2	50	1600	1,6	360	16	169,8	22,64	0,85	935	16,6
2	50	1600	2	240	16	318,3	42,44	0,85	623	20,8
2	50	1600	2	320	16	238,7	31,83	0,85	831	20,8
2	50	1600	2	360	16	212,2	28,29	0,85	935	20,8
2	50	2000	0,63	240	16	100,3	13,37	0,85	762	8,0
2	50	2000	0,63	320	16	75,2	10,03	0,85	1016	8,0
2	50	2000	1	240	16	159,2	21,22	0,85	762	12,7
2	50	2000	1	320	16	119,4	15,92	0,85	1016	12,7
2	50	2000	1,6	240	16	254,6	33,95	0,85	762	20,3
2	50	2000	1,6	320	16	191,0	25,46	0,85	1016	20,3
2	50	2000	2	240	16	318,3	42,44	0,85	762	25,4
2	50	2000	2	320	16	238,7	31,83	0,85	1016	25,4

Note 1

Note 2

Note 3

Note 4

max 1020

G-400 T2 | Note / Notes

Brake Type: DQ02 - Standard 205 V DC - Other voltages on request. DQXY certified brake against Overspeed in upward direction and as UCM (EN 81-20:2020, EN 81-50:2020) with reference to Lift Directive 2014/33/EU.

Encoder Type: Absolute encoder with EnDat Interface or Incremental sin/cos, both with 2048 ppr

Duty-cycle: Max 240 sts/h - 40% ED without fans.
Max 240 sts/h - 50% ED with fans activated by thermocontacts inside motor.

Traction sheave: Traction sheave length: 120 mm. Available length 150 mm for Ø240, Ø320, Ø360 and Ø400.

Note 1: For higher ropes weight, please consult sales/technical services of Alberto Sassi SpA.

Note 2: Details on ropes/grooves provided upon lift data. Suitable for steel core ropes or also for plastic coated ropes.

Note 3: For frequencies lower than 5 Hz, please consult your inverter supplier.

Note 4: Shaft efficiency includes divertor pulleys efficiency by considering: 3 divertors for roping 2:1. Values are supposed.

G-400 T3

Tiro	Peso funi max	Portata	Velocità cabina	Ø Puleggia	Poli	Velocità	Frequenza	Efficienza vano	Coppia	Potenza in uscita
Roping	Max Ropes Weight	Duty Load	Cabin Speed	Sheave Diameter	Poles	Speed	Frequency	Shaft Efficiency	Torque	Power Output
	[kg]	[kg]	[m/s]	[mm]		[rpm]	[Hz]		[Nm]	[kW]
1	35	630	0,63	520	16	23,1	3,09	0,85	1050	2,5
1	35	630	0,63	560	16	21,5	2,86	0,85	1131	2,5
1	35	630	0,63	600	16	20,1	2,67	0,85	1212	2,5
1	35	630	1	520	16	36,7	4,90	0,85	1050	4,0
1	35	630	1	560	16	34,1	4,55	0,85	1131	4,0
1	35	630	1	600	16	31,8	4,24	0,85	1212	4,0
1	35	630	1,6	520	16	58,8	7,84	0,85	1050	6,5
1	35	630	1,6	560	16	54,6	7,28	0,85	1131	6,5
1	35	630	1,6	600	16	50,9	6,79	0,85	1212	6,5
1	35	630	2,5	520	16	91,8	12,24	0,85	1050	10,1
1	35	630	2,5	560	16	85,3	11,37	0,85	1131	10,1
1	35	630	2,5	600	16	79,6	10,61	0,85	1212	10,1
1	35	800	0,63	400	16	30,1	4,01	0,85	1004	3,2
1	35	800	0,63	450	16	26,7	3,57	0,85	1130	3,2
1	35	800	0,63	480	16	25,1	3,34	0,85	1205	3,2
1	35	800	1	400	16	47,7	6,37	0,85	1004	5,0
1	35	800	1	450	16	42,4	5,66	0,85	1130	5,0
1	35	800	1	480	16	39,8	5,31	0,85	1205	5,0
1	35	800	1,6	400	16	76,4	10,19	0,85	1004	8,0
1	35	800	1,6	450	16	67,9	9,05	0,85	1130	8,0
1	35	800	1,6	480	16	63,7	8,49	0,85	1205	8,0
1	35	800	2,5	400	16	119,4	15,92	0,85	1004	12,6
1	35	800	2,5	450	16	106,1	14,15	0,85	1130	12,6
1	35	800	2,5	480	16	99,5	13,26	0,85	1205	12,6
1	35	1000	0,63	320	16	37,6	5,01	0,85	988	3,9
1	35	1000	0,63	360	16	33,4	4,46	0,85	1111	3,9
1	35	1000	0,63	400	16	30,1	4,01	0,85	1235	3,9
1	35	1000	1	320	16	59,7	7,96	0,85	988	6,2
1	35	1000	1	360	16	53,1	7,07	0,85	1111	6,2
1	35	1000	1	400	16	47,7	6,37	0,85	1235	6,2
1	35	1000	1,6	320	16	95,5	12,73	0,85	988	9,9
1	35	1000	1,6	360	16	84,9	11,32	0,85	1111	9,9
1	35	1000	1,6	400	16	76,4	10,19	0,85	1235	9,9
1	35	1000	2,5	320	16	149,2	19,89	0,85	988	15,4
1	35	1000	2,5	360	16	132,6	17,68	0,85	1111	15,4
1	35	1000	2,5	400	16	119,4	15,92	0,85	1235	15,4
1	35	1250	0,63	320	16	37,6	5,01	0,85	1219	4,8
1	35	1250	1	320	16	59,7	7,96	0,85	1219	7,6
1	35	1250	1,6	320	16	95,5	12,73	0,85	1219	12,2
1	35	1250	2	320	16	119,4	15,92	0,85	1219	15,2
1	35	1250	2,5	320	16	149,2	19,89	0,85	1219	19,0
2	35	1000	0,63	600	16	40,1	5,35	0,85	987	4,1
2	35	1000	0,63	650	16	37,0	4,94	0,85	1069	4,1
2	35	1000	1	600	16	63,7	8,49	0,85	987	6,6
2	35	1000	1	650	16	58,8	7,84	0,85	1069	6,6
2	35	1000	1,6	600	16	101,9	13,58	0,85	987	10,5
2	35	1000	1,6	650	16	94,0	12,54	0,85	1069	10,5
2	35	1000	2,5	600	16	159,2	21,22	0,85	987	16,4
2	35	1000	2,5	650	16	146,9	19,59	0,85	1069	16,4
2	35	1250	0,63	480	16	50,1	6,68	0,85	963	5,1
2	35	1250	0,63	520	16	46,3	6,17	0,85	1043	5,1
2	35	1250	0,63	560	16	43,0	5,73	0,85	1123	5,1
2	35	1250	0,63	600	16	40,1	5,35	0,85	1203	5,1



Tiro	Peso funi max	Portata	Velocità cabina	Ø Puleggia	Poli	Velocità	Frequenza	Efficienza vano	Coppia	Potenza in uscita
Roping	Max Ropes Weight	Duty Load	Cabin Speed	Sheave Diameter	Poles	Speed	Frequency	Shaft Efficiency	Torque	Power Output
	[kg]	[kg]	[m/s]	[mm]		[rpm]	[Hz]		[Nm]	[kW]
2	35	1250	1	480	16	79,6	10,61	0,85	963	8,0
2	35	1250	1	520	16	73,5	9,79	0,85	1043	8,0
2	35	1250	1	560	16	68,2	9,09	0,85	1123	8,0
2	35	1250	1	600	16	63,7	8,49	0,85	1203	8,0
2	35	1250	1,6	480	16	127,3	16,98	0,85	963	12,8
2	35	1250	1,6	520	16	117,5	15,67	0,85	1043	12,8
2	35	1250	1,6	560	16	109,1	14,55	0,85	1123	12,8
2	35	1250	1,6	600	16	101,9	13,58	0,85	1203	12,8
2	35	1250	2,5	480	16	198,9	26,53	0,85	963	20,1
2	35	1250	2,5	520	16	183,6	24,49	0,85	1043	20,1
2	35	1250	2,5	560	16	170,5	22,74	0,85	1123	20,1
2	35	1250	2,5	600	16	159,2	21,22	0,85	1203	20,1
2	35	1600	0,63	360	16	66,8	8,91	0,85	904	6,3
2	35	1600	0,63	400	16	60,2	8,02	0,85	1004	6,3
2	35	1600	0,63	450	16	53,5	7,13	0,85	1130	6,3
2	35	1600	0,63	480	16	50,1	6,68	0,85	1205	6,3
2	35	1600	1	360	16	106,1	14,15	0,85	904	10,0
2	35	1600	1	400	16	95,5	12,73	0,85	1004	10,0
2	35	1600	1	450	16	84,9	11,32	0,85	1130	10,0
2	35	1600	1	480	16	79,6	10,61	0,85	1205	10,0
2	35	1600	1,6	360	16	169,8	22,64	0,85	904	16,1
2	35	1600	1,6	400	16	152,8	20,37	0,85	1004	16,1
2	35	1600	1,6	450	16	135,8	18,11	0,85	1130	16,1
2	35	1600	1,6	480	16	127,3	16,98	0,85	1205	16,1
2	35	1600	2,5	360	16	265,3	35,37	0,85	904	25,1
2	35	1600	2,5	400	16	238,7	31,83	0,85	1004	25,1
2	35	1600	2,5	450	16	212,2	28,29	0,85	1130	25,1
2	35	1600	2,5	480	16	198,9	26,53	0,85	1205	25,1
2	35	2000	0,63	320	16	75,2	10,03	0,85	988	7,8
2	35	2000	0,63	360	16	66,8	8,91	0,85	1111	7,8
2	35	2000	0,63	400	16	60,2	8,02	0,85	1235	7,8
2	35	2000	1	320	16	119,4	15,92	0,85	988	12,3
2	35	2000	1	360	16	106,1	14,15	0,85	1111	12,3
2	35	2000	1	400	16	95,5	12,73	0,85	1235	12,3
2	35	2000	1,6	320	16	191,0	25,46	0,85	988	19,8
2	35	2000	1,6	360	16	169,8	22,64	0,85	1111	19,8
2	35	2000	1,6	400	16	152,8	20,37	0,85	1235	19,8
2	35	2000	2,5	320	16	298,4	39,79	0,85	988	30,9
2	35	2000	2,5	360	16	265,3	35,37	0,85	1111	30,9
2	35	2000	2,5	400	16	238,7	31,83	0,85	1235	30,9

Note 1

Note 2

Note 3

Note 4

max 1250

G-400 T3 | Note / Notes

Brake Type: DQ03, Standard 205 V DC. Other voltages on request. DQXY certified brake against Overspeed in upward direction and as UCM (EN 81-20:2020, EN 81-50:2020) with reference to Lift Directive 2014/33/EU.

Encoder Type: Absolute encoder with EnDat Interface or Incremental sin/cos, both with 2048 ppr

Duty-cycle: Max 180 sts/h - 40% ED with fans activated by thermocontacts inside motor.

Traction sheave: Traction sheave length: 120 mm. Available length 150 mm for Ø240, Ø320, Ø360 and Ø400.

Note 1: For higher ropes weight, please consult sales/technical services of Alberto Sassi SpA.

Note 2: Details on ropes/grooves provided upon lift data. Suitable for steel core ropes or also for plastic coated ropes.

Note 3: For frequencies lower than 5 Hz, please consult your inverter supplier.

Note 4: Shaft efficiency includes divertor pulleys efficiency by considering: 3 divertors for roping 2:1. Values are supposed.

**G-400****Combinazione funi / Ropes combination**

Tiro / Roping 1/1 · Corsa / Travel 30 mt						
Portata Duty load [kg]	Velocità Speed [m/s]	Puleggia Sheave [mm]	Combinazione funi Ropes combination	N° funi max Max ropes nr.	Peso cabina Cabin weight [kg]	
320	0,63 – 2,50	210-240	5÷7 x ø 6/6,5	8 ÷ 10 x ø 6/6,5	450	550
	0,63 – 2,50	320	4÷5 x ø 8	10 x ø 8		
	0,63 – 2,50	360	4÷5 x ø 9	10 x ø 9		
	0,63 – 2,50	400	3÷4 x ø 10	10 x ø 10		
450	0,63 – 2,50	210-240	6÷8 x ø 6/6,5	8 ÷ 10 x ø 6,5	650	850
	0,63 – 2,50	320	6÷7 x ø 8	10 x ø 8		
	0,63 – 2,50	360	5÷6 x ø 9	10 x ø 9		
	0,63 – 2,50	400	4÷5 x ø 10	10 x ø 10		
	0,63 – 2,50	450	4÷5 x ø 11	6 x ø 11		
	0,63 – 2,50	480	3÷4 x ø 11/12	6 x ø 11/12		
	0,63 – 2,50	520	3÷4 x ø 13	5 x ø 13		
	0,63 – 2,50	560	3÷4 x ø 14	5 x ø 14		
630	0,63 – 2,50	210-240	7÷9 x ø 6/6,5	8 ÷ 10 x ø 6/6,5	850	1050
	0,63 – 2,50	320	6÷8 x ø 8	10 x ø 8		
	0,63 – 2,50	360	6÷8 x ø 9	10 x ø 9		
	0,63 – 2,50	400	5÷6 x ø 10	10 x ø 10		
	0,63 – 2,50	450	5÷6 x ø 11	6 x ø 11		
	0,63 – 2,50	480	4÷5 x ø 11/12	6 x ø 11/12		
800	0,63 – 2,50	210-240	8÷9 x ø 6/6,5	8 ÷ 10 x ø 6/6,5	850	1200
	0,63 – 2,50	320	7÷8 x ø 8	10 x ø 8		
	0,63 – 2,50	360	7÷8 x ø 9	10 x ø 9		
	0,63 – 2,50	400	5÷6 x ø 10	10 x ø 10		
	0,63 – 2,50	450	5÷6 x ø 11	6 x ø 11		
	0,63 – 2,50	480	4÷5 x ø 11/12	6 x ø 11/12		
1000	0,63 – 2,50	240	9÷10 x ø 6,5	10 x ø 6,5	900	1250
	0,63 – 2,50	320	8 x ø 8	10 x ø 8		
	0,63 – 2,50	360	8 x ø 9	10 x ø 9		
	0,63 – 2,50	400	6 x ø 10	10 x ø 10		

Tiro / Roping 2/1 · Corsa / Travel 30 mt						
Portata Duty load [kg]	Velocità Speed [m/s]	Puleggia Sheave [mm]	Combinazione funi Ropes combination	N° funi max Max ropes nr.	Peso cabina Cabin weight [kg]	
320	0,63 – 2,50	210-240	4÷5 ø 6/6,5	8 ÷ 10 x ø 6/6,5	500	600
	0,63 – 2,50	320	3÷4 x ø 8	10 x ø 8		
	0,63 – 2,50	360	3÷4 x ø 9	10 x ø 9		
	0,63 – 2,50	400	3÷4 x ø 10	10 x ø 10		
450	0,63 – 2,50	210-240	5÷6 x ø 6/6,5	8 ÷ 10 x ø 6/6,5	700	900
	0,63 – 2,50	320	4÷5 x ø 8	10 x ø 8		
	0,63 – 2,50	360	4÷5 x ø 9	10 x ø 9		
	0,63 – 2,50	400	3÷4 x ø 10	10 x ø 10		
	0,63 – 2,50	450	3÷4 x ø 11	6 x ø 11		
	0,63 – 2,50	480	3÷4 x ø 11/12	6 x ø 11/12		
	0,63 – 2,50	520	3÷4 x ø 13	5 x ø 13		
	0,63 – 2,50	560	3÷4 x ø 14	5 x ø 14		
	0,63 – 2,50	600	3÷4 x ø 15	5 x ø 15		



GEARLESS

| G-400 |

ALBERTO SASSI

49

Tiro / Roping 2/1 · Corsa / Travel 30 mt					
Portata Duty load [kg]	Velocità Speed [m/s]	Puleggia Sheave [mm]	Combinazione funi Ropes combination	N° funi max Max ropes nr.	Peso cabina Cabin weight [kg]
630	0,63 – 2,50	210-240	5÷7 x ø 6/6,5	10 x ø 6/6,5	900 1100
	0,63 – 2,50	320	5÷6 x ø 8	10 x ø 8	
	0,63 – 2,50	360	4÷5 x ø 9	10 x ø 9	
	0,63 – 2,50	400	3÷5 x ø 10	10 x ø 10	
	0,63 – 2,50	450	3÷4 x ø 11	6 x ø 11	
	0,63 – 2,50	480	3÷4 x ø 11/12	6 x ø 11/12	
	0,63 – 2,50	520	3÷4 x ø 13	5 x ø 13	
	0,63 – 2,50	560	3÷4 x ø 14	5 x ø 14	
	0,63 – 2,50	600	3÷4 x ø 15	5 x ø 15	
800	0,63 – 2,50	210-240	6÷7 x ø 6/6,5	10 x ø 6/6,5	900 1250
	0,63 – 2,50	320	5÷6 x ø 8	10 x ø 8	
	0,63 – 2,50	360	5÷6 x ø 9	10 x ø 9	
	0,63 – 2,50	400	4÷5 x ø 10	10 x ø 10	
	0,63 – 2,50	450	4÷5 x ø 11	6 x ø 11	
	0,63 – 2,50	480	4÷5 x ø 11/12	6 x ø 11/12	
	0,63 – 2,50	520	3÷4 x ø 13	5 x ø 13	
	0,63 – 2,50	560	3÷4 x ø 14	5 x ø 14	
	0,63 – 2,50	600	3÷4 x ø 15	5 x ø 15	
1000	0,63 – 2,50	210-240	7÷8 x ø 6/6,5	10 x ø 6/6,5	1100 1400
	0,63 – 2,50	320	7÷8 x ø 8	10 x ø 8	
	0,63 – 2,50	360	5÷6 x ø 9	10 x ø 9	
	0,63 – 2,50	400	4÷5 x ø 10	10 x ø 10	
	0,63 – 2,50	450	4÷5 x ø 11	6 x ø 11	
	0,63 – 2,50	480	4÷5 x ø 11/12	6 x ø 11/12	
	0,63 – 2,50	520	3÷4 x ø 13	5 x ø 13	
	0,63 – 2,50	560	3÷4 x ø 14	5 x ø 14	
	0,63 – 2,50	600	3÷4 x ø 15	5 x ø 15	
1250	0,63 – 2,50	240	8÷9 x ø 6,5	10 x ø 6,5	1250 1500
	0,63 – 2,50	320	7÷8 x ø 8	10 x ø 8	
	0,63 – 2,50	360	5÷7 x ø 9	10 x ø 9	
	0,63 – 2,50	400	4÷5 x ø 10	10 x ø 10	
	0,63 – 2,50	450	4÷5 x ø 11	6 x ø 11	
	0,63 – 2,50	480	4÷5 x ø 11/12	6 x ø 11/12	
	0,63 – 2,50	520	4÷5 x ø 13	5 x ø 13	
	0,63 – 2,50	560	3÷4 x ø 14	5 x ø 14	
	0,63 – 2,50	600	3÷4 x ø 15	5 x ø 15	
1600	0,63 – 2,50	240	9÷10 x ø 6,5	10 x ø 6,5	1500 1700
	0,63 – 2,50	320	8 x ø 8	10 x ø 8	
	0,63 – 2,50	360	7÷8 x ø 9	10 x ø 9	
	0,63 – 2,50	400	6÷7 x ø 10	10 x ø 10	
	0,63 – 2,50	450	5÷6 x ø 11	6 x ø 11	
	0,63 – 2,50	480	5÷6 x ø 11/12	6 x ø 11/12	
2000	0,63 – 2,50	240	10 x ø 6,5	10 x ø 6,5	1800 2000
	0,63 – 2,50	320	8 x ø 8	10 x ø 8	
	0,63 – 2,50	360	8 x ø 9	10 x ø 9	
	0,63 – 2,50	400	7÷8 x ø 10	10 x ø 10	

Altre combinazioni a richiesta. / Additional combination on request.

**G-500 T1**Con o senza ventole di raffreddamento
*With or without cooling fans***G-500 T2**Con ventole di raffreddamento
*With cooling fans***G-500 T1**Con o senza ventole di raffreddamento / *With or without cooling fans*

Carico statico <i>Static load [kg]</i>	7600							
Coppia / <i>Rated torque [Nm]</i>	1600							
Peso / <i>Weight [kg]</i>	510 (senza puleggia / <i>without sheave</i>)							
Portata / <i>Duty load [kg]</i>	1000	1250	1250	1600	2000	2500	2500	4000
Tiro / <i>Roping</i>	1/1	1/1	2/1	2/1	2/1	2/1	4/1	4/1
Gamma velocità cabina <i>Range of cabin speed [m/s]</i>	0,63 ÷ 2,50	0,63 ÷ 2,50	0,63 ÷ 2,50	0,63 ÷ 2,50	0,63 ÷ 2,50	0,63 ÷ 2,0	0,63 ÷ 1,60	0,63 ÷ 1,00
Gamma Ø pulegge <i>Range sheave Ø [mm]</i>	360 - 400 450	360	360 - 400 450 - 480 520 - 560 600 - 650	360 - 400 450 - 480 520 - 560	360 - 400 450	360	360 - 400 450 - 480 520 - 560 600 - 650	360 - 400 450
Max combinazione funi <i>Max roping combination [mm]</i>	n°12 Ø 9	n°12 Ø 9	n°12 Ø 9	n°12 Ø 9	n°12 Ø 9	n°12 Ø 9	n°12 Ø 9	n°12 Ø 9
	n°10 Ø 11		n°8 Ø 16	n°8 Ø 14	n°10 Ø 11		n°8 Ø 16	n°10 Ø 11
Freno / <i>Brake</i>	ROBA-STOP-SILENZIO-1300							
Poli / <i>Poles</i>	20							

G-500 T2Con ventole di raffreddamento / *With cooling fans*

Carico statico <i>Static load [kg]</i>	7600					
Coppia / <i>Rated torque [Nm]</i>	2200					
Peso / <i>Weight [kg]</i>	630 (senza puleggia / <i>without sheave</i>)					
Portata / <i>Duty load [kg]</i>	1000-1250	1600	2000	2500	4000	5000
Tiro / <i>Roping</i>	1/1	1/1	2/1	2/1	4/1	4/1
Gamma velocità cabina <i>Range of cabin speed [m/s]</i>	0,63 ÷ 2,50	0,63 ÷ 2,50	0,63 ÷ 2,50	0,63 ÷ 2,50	0,63 - 1,60	0,63 - 1,00
Gamma Ø pulegge <i>Range sheave Ø [mm]</i>	360 - 400 - 480 520 - 560 - 600 650	360 - 400	360 - 400 - 450 480 - 520 - 560 600 - 650	400 - 450 480 - 520	360 - 400 - 450 480 - 520 - 560 600	360 - 400 - 450 480 - 520
Max combinazione funi <i>Max roping combination [mm]</i>	n°12 Ø 9	n°12 Ø 9	n°12 Ø 9	n°12 Ø 10	n°12 Ø 9	n°12 Ø 9
	n°8 Ø 16	n°12 Ø 10	n°8 Ø 16	n°8 Ø 13	n°8 Ø 15	n°8 Ø 13
Freno / <i>Brake</i>	ROBA-STOP-SILENZIO-1300					
Poli / <i>Poles</i>	20					

A richiesta disponibili: Leve apertura manuale freno. Macchina certificata CSA-UL.
Available on request: Levers for hand release. CSA-UL certified machine.



G-500 Senza ventole di raffreddamento / Without cooling fans

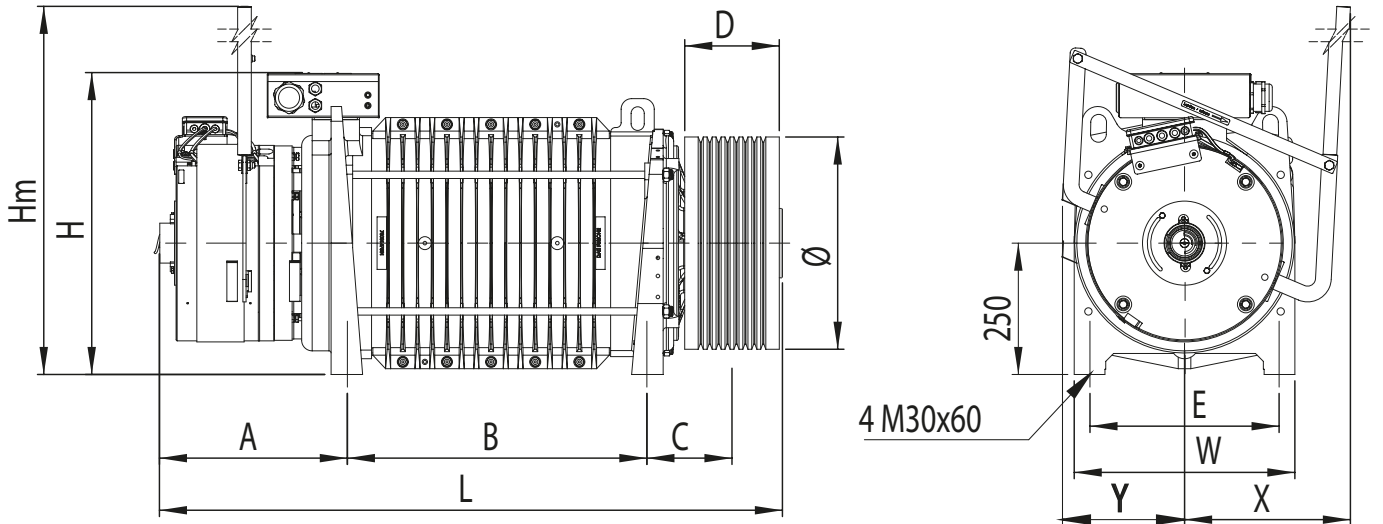

Dimensioni / Dimensions [mm]

Tipo / Type	A	L	B	C	E	W	X	Y	Hm	H	D	Ø
G-500 T1	358	1027	410	162	360	420	700 **	230	918	575	180 *	360÷650
G-500 T2	358	1187	570	162	360	420	700 **	230	918	575	180 *	360÷650

* Ø > 450 mm: pulegge con flangia.
 Ø > 450 mm: flanged traction sheave.

** Dimensione massima apertura con leva.
 Max opening dimension with lever.

G-500 Con ventole di raffreddamento / With cooling fans (T1 total fans 2, T2 total fans 4)

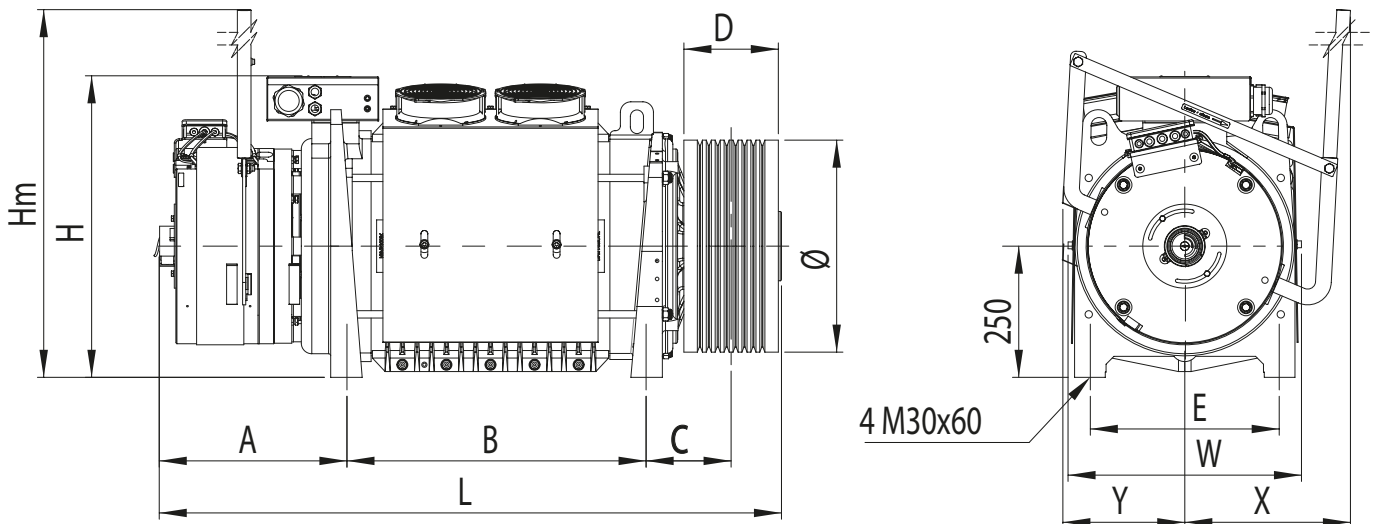

Dimensioni / Dimensions [mm]

Tipo / Type	A	L	B	C	E	W	X	Y	Hm	H	D	Ø
G-500 T1	358	1027	410	162	360	445	700 **	230	918	575	180 *	360÷650
G-500 T2	358	1187	570	162	360	445	700 **	230	918	575	180 *	360÷650

* Ø > 450 mm: pulegge con flangia.
 Ø > 450 mm: flanged traction sheave.

** Dimensione massima apertura con leva.
 Max opening dimension with lever.

G-500 T1 IP66* Senza ventole di raffreddamento / Without cooling fans

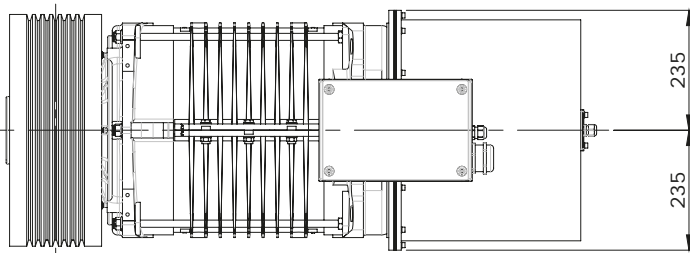
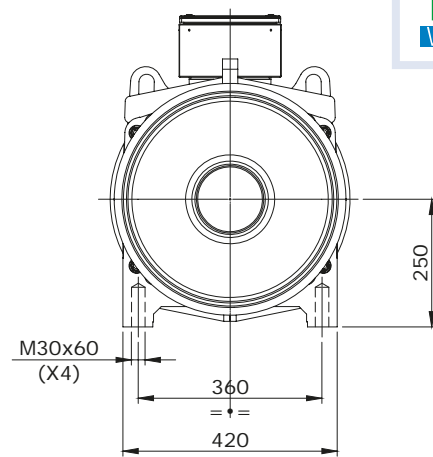
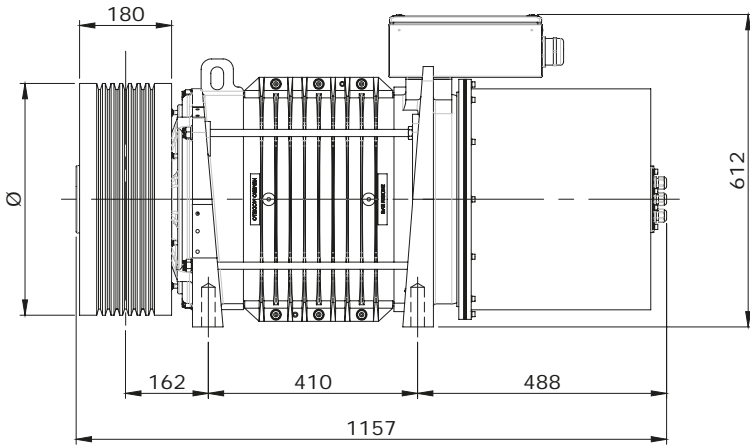

Dimensioni / Dimensions [mm]

L	Ø
1157	360 - 400 - 450
	480 - 520
	560 - 600 - 650

* Configurazione solo senza ventilatore né leve del freno.
Configuration without neither fan nor brake levers.

G-500 T2 IP66* Senza ventole di raffreddamento / Without cooling fans

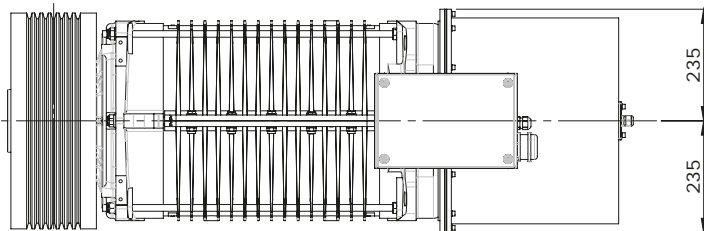
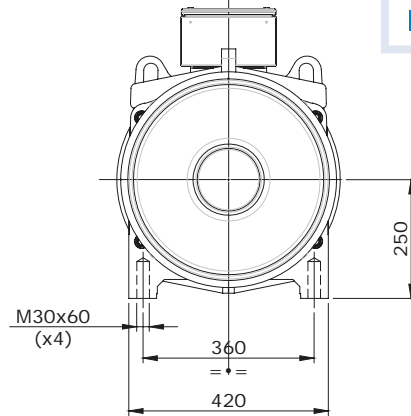
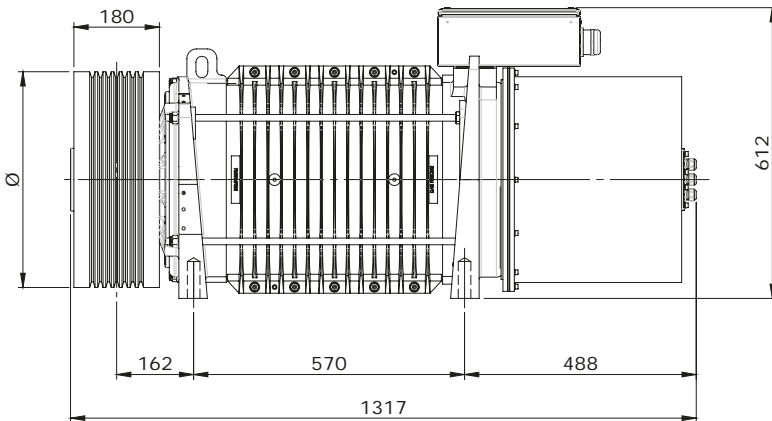

Dimensioni / Dimensions [mm]

L	Ø
1317	360 - 400 - 450
	480 - 520
	560 - 600 - 650

* Configurazione solo senza ventilatore né leve del freno.
Configuration without neither fan nor brake levers.

G-500 T1* Con ventilatore VT330 / With cooling fan

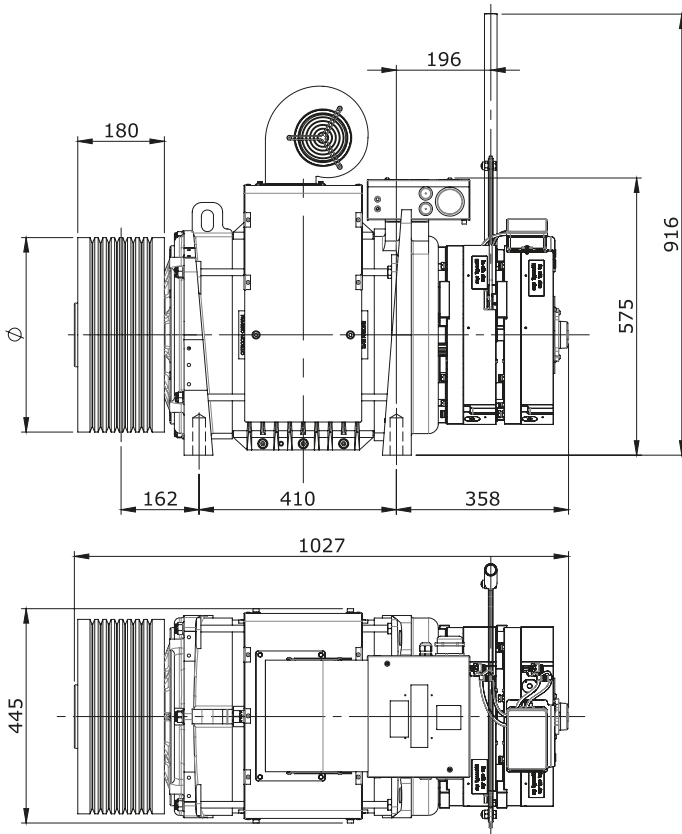

A richiesta disponibili:
Leva apertura
manuale freno.

Available on request:
Lever for
hand release.

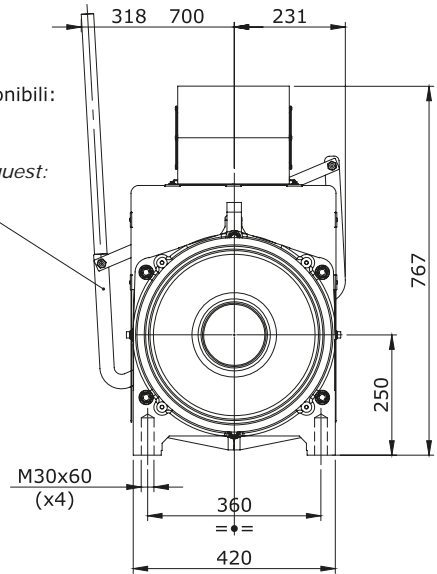

Dimensioni / Dimensions [mm]

Ø
360 - 400 - 450 - 480 - 520
560 - 600 - 650

* Per un maggiore ciclo di lavoro rispetto allo standard. Chiedere all'ufficio commerciale per maggiori informazioni.
For increased duty-cycle than the standard. Contact Sales dept. for further information.

G-500 T2* Con ventilatore VT330 / With cooling fan

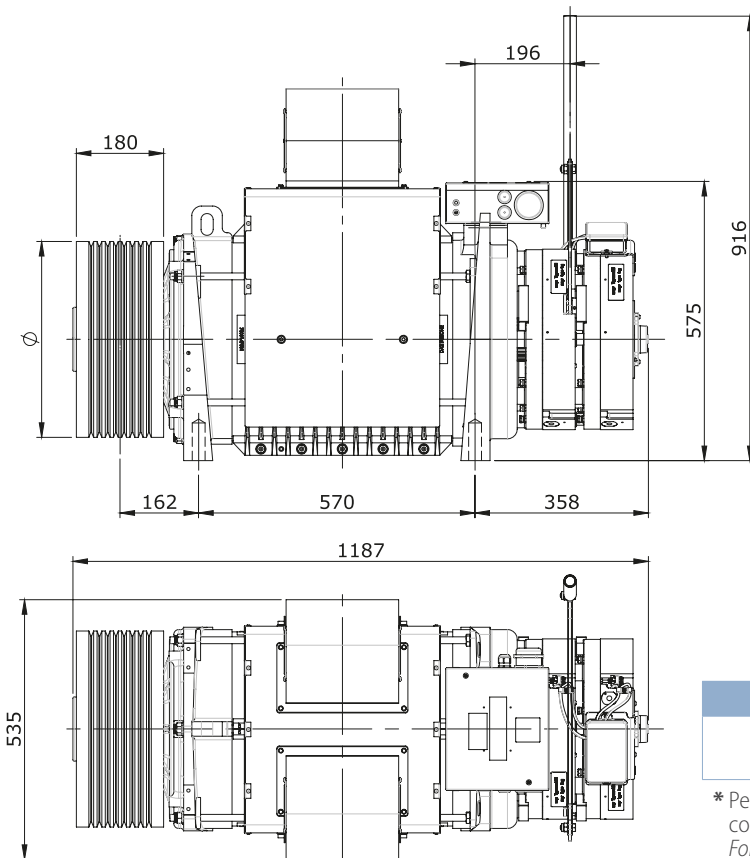

A richiesta disponibili:
Leva apertura
manuale freno.

Available on request:
Lever for
hand release.

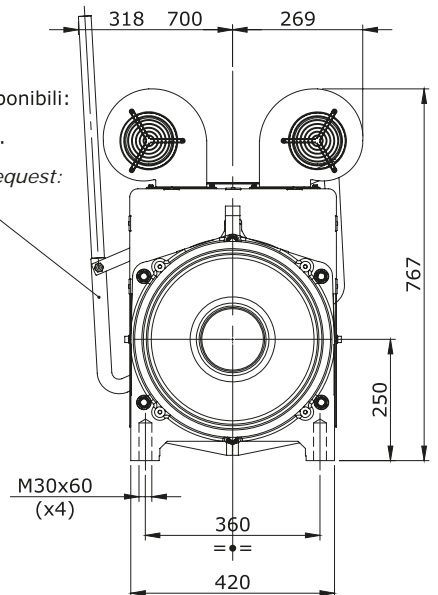

Dimensioni / Dimensions [mm]

Ø
360 - 400 - 450 - 480 - 520
560 - 600 - 650

* Per un maggiore ciclo di lavoro rispetto allo standard. Chiedere all'ufficio commerciale per maggiori informazioni.
For increased duty-cycle than the standard. Contact Sales dept. for further information.

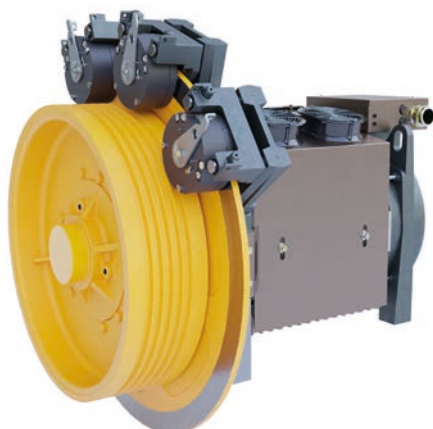
**G-525 T1****G-525 T2**

Con o senza ventole di raffreddamento
With or without cooling fans

Con ventole di raffreddamento
With cooling fans

G-525 T1**Con o senza ventole di raffreddamento / With or without cooling fans**

Carico statico Static load [kg]	7600				
Coppia / Rated torque [Nm]	1600				
Peso / Weight [kg]	620 (senza puleggia / without sheave)				
Portata / Duty load [kg]	800	1250	1600	2500	3200
Tiro / Roping	1/1	2/1	2/1	4/1	4/1
Gamma velocità cabina Range of cabin speed [m/s]	0,63 ÷ 2,50	0,63 ÷ 2,50	0,63 ÷ 2,50	0,63 ÷ 1,60	0,63 ÷ 1,00
Gamma Ø pulegge Range sheave Ø [mm]	520 - 560	520 - 560 600 - 650	520 - 560	520 - 560 600 - 650	520
Max combinazione funi Max roping combination [mm]	n°10 Ø 11	n°8 Ø 16	n°8 Ø 14	n°8 Ø 16	n°10 Ø 11
Freno / Brake	n. 3 ROBA-diskstop Size 6				
Poli / Poles	20				

G-525 T2**Con ventole di raffreddamento / With cooling fans**

Carico statico Static load [kg]	7600				
Coppia / Rated torque [Nm]	2200				
Peso / Weight [kg]	740 (senza puleggia / without sheave)				
Portata / Duty load [kg]	1000-1250	2000	2500	4000	5000
Tiro / Roping	1/1	2/1	2/1	4/1	4/1
Gamma velocità cabina Range of cabin speed [m/s]	0,63 ÷ 2,50	0,63 ÷ 2,50	0,63 ÷ 2,50	0,63 - 1,60	0,63 - 1,00
Gamma Ø pulegge Range sheave Ø [mm]	520 - 560 - 600 650	520 - 560 600 - 650	520	520 - 560 600	520
Max combinazione funi Max roping combination [mm]	n°8 Ø 16	n°8 Ø 16	n°8 Ø 13	n°8 Ø 15	n°8 Ø 13
Freno / Brake	n. 3 ROBA-diskstop Size 6				
Poli / Poles	20				

A richiesta disponibili: Macchina certificata CSA-UL.
Available on request: CSA-UL certified machine.

G-525 Senza ventole di raffreddamento / Without cooling fans

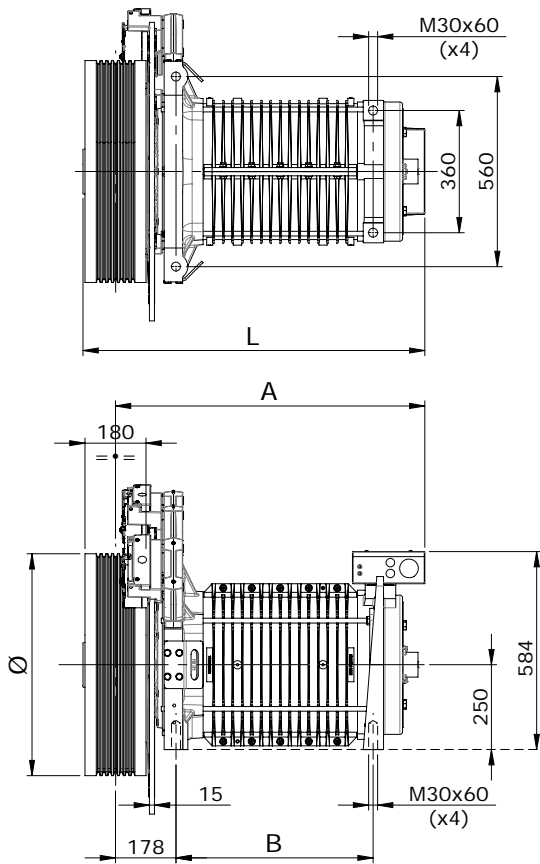

Dimensioni / Dimensions [mm]

Tipo / Type	A	B	L	Ø
G-525 T1	760	420	850	520 - 560 - 600 - 650
G-525 T2	920	580	1010	520 - 560 - 600 - 650

Posizione standard delle pinze freno / Standard Brake Calipers position

C1	C2	C3	C4	C5	C6
	•	•	•		

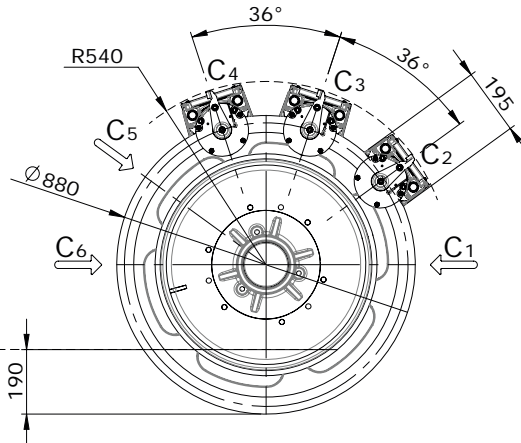

G-525 Con ventole di raffreddamento / With cooling fans (T1 total fans 2, T2 total fans 4)

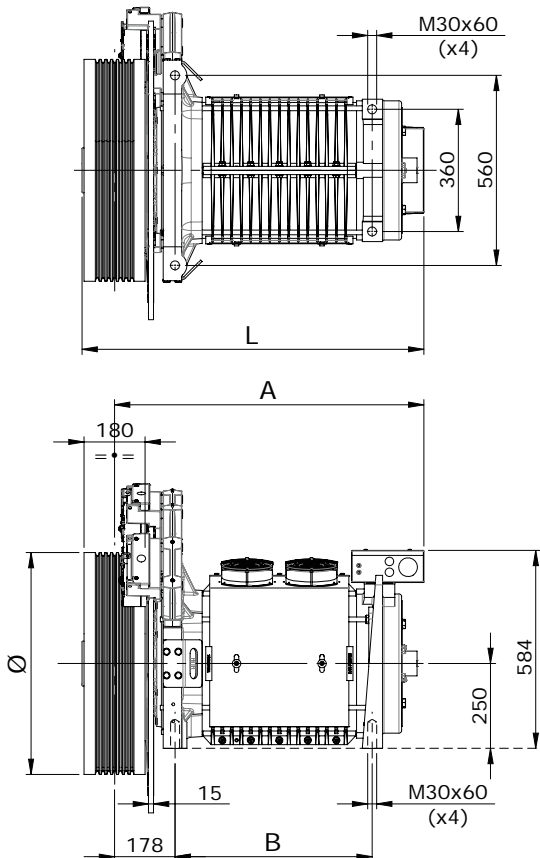

Dimensioni / Dimensions [mm]

Tipo / Type	A	B	L	Ø
G-525 T1	760	420	850	520 - 560 - 600 - 650
G-525 T2	920	580	1010	520 - 560 - 600 - 650

Posizione standard delle pinze freno / Standard Brake Calipers position

C1	C2	C3	C4	C5	C6
	•	•	•		

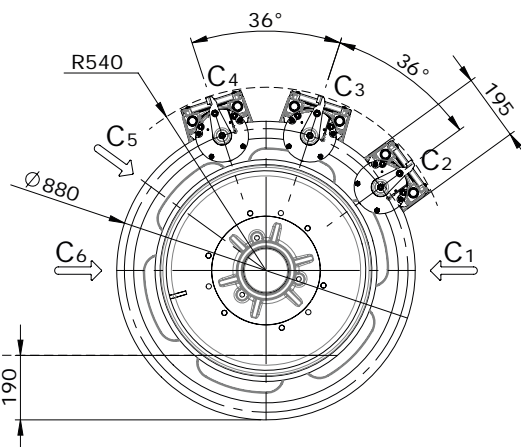



G-500 T1 · G-525 T1 | Dati tecnici / Technical data

Tiro	Peso funi max	Portata	Velocità cabina	Ø Puleggia	Poli	Velocità	Frequenza	Efficienza vano	Coppia	Potenza in uscita
Roping	Max Ropes Weight	Duty Load	Cabin Speed	Sheave Diameter	Poles	Speed	Frequency	Shaft Efficiency	Torque	Power Output
	[kg]	[kg]	[m/s]	[mm]		[rpm]	[Hz]		[Nm]	[kW]
1	80	800	0,63	360	20	33,4	5,57	0,85	997	3,5
1	80	800	0,63	400	20	30,1	5,01	0,85	1108	3,5
1	80	800	0,63	450	20	26,7	4,46	0,85	1246	3,5
1	80	800	0,63	480	20	25,1	4,18	0,85	1330	3,5
1	80	800	0,63	520*	20	23,1	3,86	0,85	1440	3,5
1	80	800	0,63	560*	20	21,5	3,58	0,85	1551	3,5
1	80	800	1	360	20	53,1	8,84	0,85	997	5,5
1	80	800	1	400	20	47,7	7,96	0,85	1108	5,5
1	80	800	1	450	20	42,4	7,07	0,85	1246	5,5
1	80	800	1	480	20	39,8	6,63	0,85	1330	5,5
1	80	800	1	520*	20	36,7	6,12	0,85	1440	5,5
1	80	800	1	560*	20	34,1	5,68	0,85	1551	5,5
1	80	800	1,6	360	20	84,9	14,15	0,85	997	8,9
1	80	800	1,6	400	20	76,4	12,73	0,85	1108	8,9
1	80	800	1,6	450	20	67,9	11,32	0,85	1246	8,9
1	80	800	1,6	480	20	63,7	10,61	0,85	1330	8,9
1	80	800	1,6	520*	20	58,8	9,79	0,85	1440	8,9
1	80	800	1,6	560*	20	54,6	9,09	0,85	1551	8,9
1	80	800	2,5	360	20	132,6	22,10	0,85	997	13,8
1	80	800	2,5	400	20	119,4	19,89	0,85	1108	13,8
1	80	800	2,5	450	20	106,1	17,68	0,85	1246	13,8
1	80	800	2,5	480	20	99,5	16,58	0,85	1330	13,8
1	80	800	2,5	520*	20	91,8	15,30	0,85	1440	13,8
1	80	800	2,5	560*	20	85,3	14,21	0,85	1551	13,8
1	80	1000	0,63	360	20	33,4	5,57	0,85	1205	4,2
1	80	1000	0,63	400	20	30,1	5,01	0,85	1339	4,2
1	80	1000	0,63	450	20	26,7	4,46	0,85	1506	4,2
1	80	1000	1	360	20	53,1	8,84	0,85	1205	6,7
1	80	1000	1	400	20	47,7	7,96	0,85	1339	6,7
1	80	1000	1	450	20	42,4	7,07	0,85	1506	6,7
1	80	1000	1,6	360	20	84,9	14,15	0,85	1205	10,7
1	80	1000	1,6	400	20	76,4	12,73	0,85	1339	10,7
1	80	1000	1,6	450	20	67,9	11,32	0,85	1506	10,7
1	80	1000	2,5	360	20	132,6	22,10	0,85	1205	16,7
1	80	1000	2,5	400	20	119,4	19,89	0,85	1339	16,7
1	80	1000	2,5	450	20	106,1	17,68	0,85	1506	16,7
1	80	1250	0,63	360	20	33,4	5,57	0,85	1465	5,1
1	80	1250	1	360	20	53,1	8,84	0,85	1465	8,1
1	80	1250	1,6	360	20	84,9	14,15	0,85	1465	13,0
1	80	1250	2	360	20	106,1	17,68	0,85	1465	16,3
1	80	1250	2,5	360	20	132,6	22,10	0,85	1465	20,3
2	80	1250	0,63	560*	20	43,0	7,16	0,85	1268	5,7

Tiro	Peso funi max	Portata	Velocità cabina	Ø Puleggia	Poli	Velocità	Frequenza	Efficienza vano	Coppia	Potenza in uscita
Roping	Max Ropes Weight	Duty Load	Cabin Speed	Sheave Diameter	Poles	Speed	Frequency	Shaft Efficiency	Torque	Power Output
	[kg]	[kg]	[m/s]	[mm]		[rpm]	[Hz]		[Nm]	[kW]
2	80	1250	0,63	600*	20	40,1	6,68	0,85	1359	5,7
2	80	1250	0,63	650*	20	37,0	6,17	0,85	1472	5,7
2	80	1250	1	560*	20	68,2	11,37	0,85	1268	9,1
2	80	1250	1	600*	20	63,7	10,61	0,85	1359	9,1
2	80	1250	1	650*	20	58,8	9,79	0,85	1472	9,1
2	80	1250	1,6	560*	20	109,1	18,19	0,85	1268	14,5
2	80	1250	1,6	600*	20	101,9	16,98	0,85	1359	14,5
2	80	1250	1,6	650*	20	94,0	15,67	0,85	1472	14,5
2	80	1250	2	560*	20	136,4	22,74	0,85	1268	18,1
2	80	1250	2	600*	20	127,3	21,22	0,85	1359	18,1
2	80	1250	2	650*	20	117,5	19,59	0,85	1472	18,1
2	80	1250	2,5	560*	20	170,5	28,42	0,85	1268	22,6
2	80	1250	2,5	600*	20	159,2	26,53	0,85	1359	22,6
2	80	1250	2,5	650*	20	146,9	24,49	0,85	1472	22,6
2	80	1600	0,63	480	20	50,1	8,36	0,85	1330	7,0
2	80	1600	0,63	520*	20	46,3	7,71	0,85	1440	7,0
2	80	1600	0,63	560*	20	43,0	7,16	0,85	1551	7,0
2	80	1600	1	480	20	79,6	13,26	0,85	1330	11,1
2	80	1600	1	520*	20	73,5	12,24	0,85	1440	11,1
2	80	1600	1	560*	20	68,2	11,37	0,85	1551	11,1
2	80	1600	1,6	480	20	127,3	21,22	0,85	1330	17,7
2	80	1600	1,6	520*	20	117,5	19,59	0,85	1440	17,7
2	80	1600	1,6	560*	20	109,1	18,19	0,85	1551	17,7
2	80	1600	2	480	20	159,2	26,53	0,85	1330	22,2
2	80	1600	2	520*	20	146,9	24,49	0,85	1440	22,2
2	80	1600	2	560*	20	136,4	22,74	0,85	1551	22,2
2	80	1600	2,5	480	20	198,9	33,16	0,85	1330	27,7
2	80	1600	2,5	520*	20	183,6	30,61	0,85	1440	27,7
2	80	1600	2,5	560*	20	170,5	28,42	0,85	1551	27,7
2	80	2000	0,63	360	20	66,8	11,14	0,85	1205	8,4
2	80	2000	0,63	400	20	60,2	10,03	0,85	1339	8,4
2	80	2000	0,63	450	20	53,5	8,91	0,85	1506	8,4
2	80	2000	1	360	20	106,1	17,68	0,85	1205	13,4
2	80	2000	1	400	20	95,5	15,92	0,85	1339	13,4
2	80	2000	1	450	20	84,9	14,15	0,85	1506	13,4
2	80	2000	1,6	360	20	169,8	28,29	0,85	1205	21,4
2	80	2000	1,6	400	20	152,8	25,46	0,85	1339	21,4
2	80	2000	1,6	450	20	135,8	22,64	0,85	1506	21,4
2	80	2000	2	360	20	212,2	35,37	0,85	1205	26,8
2	80	2000	2	400	20	191,0	31,83	0,85	1339	26,8
2	80	2000	2	450	20	169,8	28,29	0,85	1506	26,8
2	80	2000	2,5	400	20	238,7	39,79	0,85	1339	33,5
2	80	2000	2,5	450	20	212,2	35,37	0,85	1506	33,5
2	80	2500	0,63	360	20	66,8	11,14	0,85	1465	10,3
2	80	2500	1	360	20	106,1	17,68	0,85	1465	16,3

Tiro	Peso funi max	Portata	Velocità cabina	Ø Puleggia	Poli	Velocità	Frequenza	Efficienza vano	Coppia	Potenza in uscita
Roping	Max Ropes Weight	Duty Load	Cabin Speed	Sheave Diameter	Poles	Speed	Frequency	Shaft Efficiency	Torque	Power Output
	[kg]	[kg]	[m/s]	[mm]		[rpm]	[Hz]		[Nm]	[kW]
2	80	2500	1,6	360	20	169,8	28,29	0,85	1465	26,0
2	80	2500	2	360	20	212,2	35,37	0,85	1465	32,5
4	80	2500	0,63	360	20	133,7	22,28	0,82	845	11,8
4	80	2500	0,63	400	20	120,3	20,05	0,82	939	11,8
4	80	2500	0,63	450	20	107,0	17,83	0,82	1057	11,8
4	80	2500	0,63	480	20	100,3	16,71	0,82	1127	11,8
4	80	2500	0,63	520*	20	92,6	15,43	0,82	1221	11,8
4	80	2500	0,63	560*	20	85,9	14,32	0,82	1315	11,8
4	80	2500	0,63	600*	20	80,2	13,37	0,82	1409	11,8
4	80	2500	0,63	650*	20	74,0	12,34	0,82	1526	11,8
4	80	2500	1	360	20	212,2	35,37	0,82	845	18,8
4	80	2500	1	400	20	191,0	31,83	0,82	939	18,8
4	80	2500	1	450	20	169,8	28,29	0,82	1057	18,8
4	80	2500	1	480	20	159,2	26,53	0,82	1127	18,8
4	80	2500	1	520*	20	146,9	24,49	0,82	1221	18,8
4	80	2500	1	560*	20	136,4	22,74	0,82	1315	18,8
4	80	2500	1	600*	20	127,3	21,22	0,82	1409	18,8
4	80	2500	1	650*	20	117,5	19,59	0,82	1526	18,8
4	80	2500	1,6	480	20	254,6	42,44	0,82	1127	30,1
4	80	2500	1,6	520*	20	235,1	39,18	0,82	1221	30,1
4	80	2500	1,6	560*	20	218,3	36,38	0,82	1315	30,1
4	80	2500	1,6	600*	20	203,7	33,95	0,82	1409	30,1
4	80	2500	1,6	650*	20	188,0	31,34	0,82	1526	30,1
4	80	4000	0,63	360	20	133,7	22,28	0,82	1249	17,5
4	80	4000	0,63	400	20	120,3	20,05	0,82	1388	17,5
4	80	4000	0,63	450	20	107,0	17,83	0,82	1561	17,5
4	80	4000	1	360	20	212,2	35,37	0,82	1249	27,8
4	80	4000	1	400	20	191,0	31,83	0,82	1388	27,8
4	80	4000	1	450	20	169,8	28,29	0,82	1561	27,8

Note 1

Note 2

Note 3

Note 4

max 1600

G-500 T1 · G-525 T1 | Note / Notes

Encoder Type: Absolute encoder with EnDat Interface or Incremental sin/cos, both with 2048 ppr

Duty-cycle: Max 180 sts/h - 30% ED without fans.
Max 240 sts/h - 50% ED with fans activated by thermocontacts inside motor.

Traction sheave: Traction sheave width: 180 mm.

Note 1: For higher ropes weight, please consult sales/technical services of Alberto Sassi SpA.

Note 2: Details on ropes/grooves provided upon lift data.

Note 3: For frequencies lower than 5 Hz, please consult your inverter supplier.

Note 4: Shaft efficiency includes divertor pulleys efficiency by considering: 3 divertors for roping 2:1. Values are supposed.

G-500 T1 | Note / Notes

Brake Type: Mayr - ROBA-STOP-SILENZIO-1300 207 Vdc. Hand release lever available on request.

MAYR's certified brake against Overspeed in upward direction and as UCM (EN 81-20:2020, EN 81-50:2020) with reference to Lift Directive 2014/33/EU.

G-525 T1 | Note / Notes

Brake Type: Mayr - ROBA-diskstop size 6, 104 Vdc with overexcitation. Hand release lever always available. Configuration with 3 calipers: position may vary according to roping directions (see drawing).

MAYR's certified brake against Overspeed in upward direction and as UCM (EN 81-20:2020, EN 81-50:2020) with reference to Lift Directive 2014/33/EU.

* Available performances for G-525 T1 and G-500 T1.

For diameters 360 ÷ 480, performances possible only for G-500 T1.

Tiro	Peso funi max	Portata	Velocità cabina	Ø Puleggia	Poli	Velocità	Frequenza	Efficienza vano	Coppia	Potenza in uscita
Roping	Max Ropes Weight	Duty Load	Cabin Speed	Sheave Diameter	Poles	Speed	Frequency	Shaft Efficiency	Torque	Power Output
	[kg]	[kg]	[m/s]	[mm]		[rpm]	[Hz]		[Nm]	[kW]
1	80	800	0,63	560*	20	21,5	3,58	0,85	1551	3,5
1	80	800	0,63	600*	20	20,1	3,34	0,85	1662	3,5
1	80	800	1	560*	20	34,1	5,68	0,85	1551	5,5
1	80	800	1	600*	20	31,8	5,31	0,85	1662	5,5
1	80	800	1	650*	20	29,4	4,90	0,85	1800	5,5
1	80	800	1,6	560*	20	54,6	9,09	0,85	1551	8,9
1	80	800	1,6	600*	20	50,9	8,49	0,85	1662	8,9
1	80	800	1,6	650*	20	47,0	7,84	0,85	1800	8,9
1	80	800	2	560*	20	68,2	11,37	0,85	1551	11,1
1	80	800	2	600*	20	63,7	10,61	0,85	1662	11,1
1	80	800	2	650*	20	58,8	9,79	0,85	1800	11,1
1	80	800	2,5	560*	20	85,3	14,21	0,85	1551	13,8
1	80	800	2,5	600*	20	79,6	13,26	0,85	1662	13,8
1	80	800	2,5	650*	20	73,5	12,24	0,85	1800	13,8
1	80	1000	0,63	450	20	26,7	4,46	0,85	1506	4,2
1	80	1000	0,63	480	20	25,1	4,18	0,85	1607	4,2
1	80	1000	0,63	520*	20	23,1	3,86	0,85	1740	4,2
1	80	1000	0,63	560*	20	21,5	3,58	0,85	1874	4,2
1	80	1000	0,63	600*	20	20,1	3,34	0,85	2008	4,2
1	80	1000	1	450	20	42,4	7,07	0,85	1506	6,7
1	80	1000	1	480	20	39,8	6,63	0,85	1607	6,7
1	80	1000	1	520*	20	36,7	6,12	0,85	1740	6,7
1	80	1000	1	560*	20	34,1	5,68	0,85	1874	6,7
1	80	1000	1	600*	20	31,8	5,31	0,85	2008	6,7
1	80	1000	1	650*	20	29,4	4,90	0,85	2176	6,7
1	80	1000	1,6	450	20	67,9	11,32	0,85	1506	10,7
1	80	1000	1,6	480	20	63,7	10,61	0,85	1607	10,7
1	80	1000	1,6	520*	20	58,8	9,79	0,85	1740	10,7
1	80	1000	1,6	560*	20	54,6	9,09	0,85	1874	10,7
1	80	1000	1,6	600*	20	50,9	8,49	0,85	2008	10,7
1	80	1000	1,6	650*	20	47,0	7,84	0,85	2176	10,7
1	80	1000	2	450	20	84,9	14,15	0,85	1506	13,4
1	80	1000	2	480	20	79,6	13,26	0,85	1607	13,4
1	80	1000	2	520*	20	73,5	12,24	0,85	1740	13,4
1	80	1000	2	560*	20	68,2	11,37	0,85	1874	13,4
1	80	1000	2	600*	20	63,7	10,61	0,85	2008	13,4
1	80	1000	2	650*	20	58,8	9,79	0,85	2176	13,4
1	80	1000	2,5	450	20	106,1	17,68	0,85	1506	16,7
1	80	1000	2,5	480	20	99,5	16,58	0,85	1607	16,7
1	80	1000	2,5	520*	20	91,8	15,30	0,85	1740	16,7
1	80	1000	2,5	560*	20	85,3	14,21	0,85	1874	16,7
1	80	1000	2,5	600*	20	79,6	13,26	0,85	2008	16,7
1	80	1000	2,5	650*	20	73,5	12,24	0,85	2176	16,7
1	80	1250	0,63	360	20	33,4	5,57	0,85	1465	5,1

Tiro	Peso funi max	Portata	Velocità cabina	Ø Puleggia	Poli	Velocità	Frequenza	Efficienza vano	Coppia	Potenza in uscita
Roping	Max Ropes Weight	Duty Load	Cabin Speed	Sheave Diameter	Poles	Speed	Frequency	Shaft Efficiency	Torque	Power Output
	[kg]	[kg]	[m/s]	[mm]		[rpm]	[Hz]		[Nm]	[kW]
1	80	1250	0,63	400	20	30,1	5,01	0,85	1627	5,1
1	80	1250	0,63	450	20	26,7	4,46	0,85	1831	5,1
1	80	1250	0,63	480	20	25,1	4,18	0,85	1953	5,1
1	80	1250	0,63	520*	20	23,1	3,86	0,85	2115	5,1
1	80	1250	1	360	20	53,1	8,84	0,85	1465	8,1
1	80	1250	1	400	20	47,7	7,96	0,85	1627	8,1
1	80	1250	1	450	20	42,4	7,07	0,85	1831	8,1
1	80	1250	1	480	20	39,8	6,63	0,85	1953	8,1
1	80	1250	1	520*	20	36,7	6,12	0,85	2115	8,1
1	80	1250	1,6	360	20	84,9	14,15	0,85	1465	13,0
1	80	1250	1,6	400	20	76,4	12,73	0,85	1627	13,0
1	80	1250	1,6	450	20	67,9	11,32	0,85	1831	13,0
1	80	1250	1,6	480	20	63,7	10,61	0,85	1953	13,0
1	80	1250	1,6	520*	20	58,8	9,79	0,85	2115	13,0
1	80	1250	2	360	20	106,1	17,68	0,85	1465	16,3
1	80	1250	2	400	20	95,5	15,92	0,85	1627	16,3
1	80	1250	2	450	20	84,9	14,15	0,85	1831	16,3
1	80	1250	2	480	20	79,6	13,26	0,85	1953	16,3
1	80	1250	2	520*	20	73,5	12,24	0,85	2115	16,3
1	80	1250	2,5	360	20	132,6	22,10	0,85	1465	20,3
1	80	1250	2,5	400	20	119,4	19,89	0,85	1627	20,3
1	80	1250	2,5	450	20	106,1	17,68	0,85	1831	20,3
1	80	1250	2,5	480	20	99,5	16,58	0,85	1953	20,3
1	80	1250	2,5	520*	20	91,8	15,30	0,85	2115	20,3
1	80	1600	0,63	360	20	33,4	5,57	0,85	1828	6,4
1	80	1600	0,63	400	20	30,1	5,01	0,85	2031	6,4
1	80	1600	1	360	20	53,1	8,84	0,85	1828	10,2
1	80	1600	1	400	20	47,7	7,96	0,85	2031	10,2
1	80	1600	1,6	360	20	84,9	14,15	0,85	1828	16,2
1	80	1600	1,6	400	20	76,4	12,73	0,85	2031	16,2
1	80	1600	2	360	20	106,1	17,68	0,85	1828	20,3
1	80	1600	2	400	20	95,5	15,92	0,85	2031	20,3
1	80	1600	2,5	360	20	132,6	22,10	0,85	1828	25,4
1	80	1600	2,5	400	20	119,4	19,89	0,85	2031	25,4
2	80	2000	0,63	450	20	53,5	8,91	0,85	1506	8,4
2	80	2000	0,63	480	20	50,1	8,36	0,85	1607	8,4
2	80	2000	0,63	520*	20	46,3	7,71	0,85	1740	8,4
2	80	2000	0,63	560*	20	43,0	7,16	0,85	1874	8,4
2	80	2000	0,63	600*	20	40,1	6,68	0,85	2008	8,4
2	80	2000	0,63	650*	20	37,0	6,17	0,85	2176	8,4
2	80	2000	1	450	20	84,9	14,15	0,85	1506	13,4
2	80	2000	1	480	20	79,6	13,26	0,85	1607	13,4
2	80	2000	1	520*	20	73,5	12,24	0,85	1740	13,4
2	80	2000	1	560*	20	68,2	11,37	0,85	1874	13,4
2	80	2000	1	600*	20	63,7	10,61	0,85	2008	13,4

Tiro	Peso funi max	Portata	Velocità cabina	Ø Puleggia	Poli	Velocità	Frequenza	Efficienza vano	Coppia	Potenza in uscita
Roping	Max Ropes Weight	Duty Load	Cabin Speed	Sheave Diameter	Poles	Speed	Frequency	Shaft Efficiency	Torque	Power Output
	[kg]	[kg]	[m/s]	[mm]		[rpm]	[Hz]		[Nm]	[kW]
2	80	2000	1	650*	20	58,8	9,79	0,85	2176	13,4
2	80	2000	1,6	450	20	135,8	22,64	0,85	1506	21,4
2	80	2000	1,6	480	20	127,3	21,22	0,85	1607	21,4
2	80	2000	1,6	520*	20	117,5	19,59	0,85	1740	21,4
2	80	2000	1,6	560*	20	109,1	18,19	0,85	1874	21,4
2	80	2000	1,6	600*	20	101,9	16,98	0,85	2008	21,4
2	80	2000	1,6	650*	20	94,0	15,67	0,85	2176	21,4
2	80	2000	2	450	20	169,8	28,29	0,85	1506	26,8
2	80	2000	2	480	20	159,2	26,53	0,85	1607	26,8
2	80	2000	2	520*	20	146,9	24,49	0,85	1740	26,8
2	80	2000	2	560*	20	136,4	22,74	0,85	1874	26,8
2	80	2000	2	600*	20	127,3	21,22	0,85	2008	26,8
2	80	2000	2	650*	20	117,5	19,59	0,85	2176	26,8
2	80	2000	2,5	450	20	212,2	35,37	0,85	1506	33,5
2	80	2000	2,5	480	20	198,9	33,16	0,85	1607	33,5
2	80	2000	2,5	520*	20	183,6	30,61	0,85	1740	33,5
2	80	2000	2,5	560*	20	170,5	28,42	0,85	1874	33,5
2	80	2000	2,5	600*	20	159,2	26,53	0,85	2008	33,5
2	80	2000	2,5	650*	20	146,9	24,49	0,85	2176	33,5
2	80	2500	0,63	360	20	66,8	11,14	0,85	1465	10,3
2	80	2500	0,63	400	20	60,2	10,03	0,85	1627	10,3
2	80	2500	0,63	450	20	53,5	8,91	0,85	1831	10,3
2	80	2500	0,63	480	20	50,1	8,36	0,85	1953	10,3
2	80	2500	0,63	520*	20	46,3	7,71	0,85	2115	10,3
2	80	2500	1	360	20	106,1	17,68	0,85	1465	16,3
2	80	2500	1	400	20	95,5	15,92	0,85	1627	16,3
2	80	2500	1	450	20	84,9	14,15	0,85	1831	16,3
2	80	2500	1	480	20	79,6	13,26	0,85	1953	16,3
2	80	2500	1	520*	20	73,5	12,24	0,85	2115	16,3
2	80	2500	1,6	360	20	169,8	28,29	0,85	1465	26,0
2	80	2500	1,6	400	20	152,8	25,46	0,85	1627	26,0
2	80	2500	1,6	450	20	135,8	22,64	0,85	1831	26,0
2	80	2500	1,6	480	20	127,3	21,22	0,85	1953	26,0
2	80	2500	1,6	520*	20	117,5	19,59	0,85	2115	26,0
2	80	2500	2	360	20	212,2	35,37	0,85	1465	32,5
2	80	2500	2	400	20	191,0	31,83	0,85	1627	32,5
2	80	2500	2	450	20	169,8	28,29	0,85	1831	32,5
2	80	2500	2	480	20	159,2	26,53	0,85	1953	32,5
2	80	2500	2	520*	20	146,9	24,49	0,85	2115	32,5
2	80	2500	2,5	400	20	238,7	39,79	0,85	1627	40,7
2	80	2500	2,5	450	20	212,2	35,37	0,85	1831	40,7
2	80	2500	2,5	480	20	198,9	33,16	0,85	1953	40,7
2	80	2500	2,5	520*	20	183,6	30,61	0,85	2115	40,7
4	80	4000	0,63	450	20	107,0	17,83	0,82	1561	17,5
4	80	4000	0,63	480	20	100,3	16,71	0,82	1665	17,5

Tiro	Peso funi max	Portata	Velocità cabina	Ø Puleggia	Poli	Velocità	Frequenza	Efficienza vano	Coppia	Potenza in uscita
Roping	Max Ropes Weight	Duty Load	Cabin Speed	Sheave Diameter	Poles	Speed	Frequency	Shaft Efficiency	Torque	Power Output
	[kg]	[kg]	[m/s]	[mm]		[rpm]	[Hz]		[Nm]	[kW]
4	80	4000	0,63	520*	20	92,6	15,43	0,82	1804	17,5
4	80	4000	0,63	560*	20	85,9	14,32	0,82	1943	17,5
4	80	4000	0,63	600*	20	80,2	13,37	0,82	2082	17,5
4	80	4000	1	450	20	169,8	28,29	0,82	1561	27,8
4	80	4000	1	480	20	159,2	26,53	0,82	1665	27,8
4	80	4000	1	520*	20	146,9	24,49	0,82	1804	27,8
4	80	4000	1	560*	20	136,4	22,74	0,82	1943	27,8
4	80	4000	1	600*	20	127,3	21,22	0,82	2082	27,8
4	80	4000	1,6	480	20	254,6	42,44	0,82	1665	44,4
4	80	4000	1,6	520*	20	235,1	39,18	0,82	1804	44,4
4	80	4000	1,6	560*	20	218,3	36,38	0,82	1943	44,4
4	80	4000	1,6	600*	20	203,7	33,95	0,82	2082	44,4
4	80	5000	0,63	360	20	133,7	22,28	0,82	1518	21,3
4	80	5000	0,63	400	20	120,3	20,05	0,82	1687	21,3
4	80	5000	0,63	450	20	107,0	17,83	0,82	1898	21,3
4	80	5000	0,63	480	20	100,3	16,71	0,82	2024	21,3
4	80	5000	0,63	520*	20	92,6	15,43	0,82	2193	21,3
4	80	5000	1	360	20	212,2	35,37	0,82	1518	33,7
4	80	5000	1	400	20	191,0	31,83	0,82	1687	33,7
4	80	5000	1	450	20	169,8	28,29	0,82	1898	33,7
4	80	5000	1	480	20	159,2	26,53	0,82	2024	33,7
4	80	5000	1	520*	20	146,9	24,49	0,82	2193	33,7
4	80	5000	1,6	480	20	254,6	42,44	0,82	2024	54,0
4	80	5000	1,6	520*	20	235,1	39,18	0,82	2193	54,0

Note 1

Note 2

Note 3

Note 4

max 2200

G-500 T2 · G-525 T2 | Note / Notes

Encoder Type: Absolute Heidenhain with EnDat Interface - Other type on request.

Duty-cycle: Max 180 sts/h - 30% ED without fans.
Max 240 sts/h - 50% ED with fans activated by thermocontacts inside motor.

Traction sheave: Traction sheave width: 180 mm.

Note 1: For higher ropes weight, please consult sales/technical services of Alberto Sassi SpA.

Note 2: Details on ropes/grooves provided upon lift data.

Note 3: For frequencies lower than 5 Hz, please consult your inverter supplier.

Note 4: Shaft efficiency includes divertor pulleys efficiency by considering:
3 divertors for roping 2:1 and 7 divertors for roping 4:1. Values are supposed.

G-500 T2 | Note / Notes

Brake Type: Mayr - ROBA-STOP-SILENZIO-1300 207 Vdc. Hand release lever available on request.

MAYR's certified brake against Overspeed in upward direction and as UCM (EN 81-20:2020, EN 81-50:2020) with reference to Lift Directive 2014/33/EU.

G-525 T2 | Note / Notes

Brake Type: Mayr - ROBA-diskstop size 6, 104 Vdc with overexcitation. Hand release lever always available. Configuration with 3 calipers: position may vary according to roping directions (see drawing).

MAYR's certified brake against Overspeed in upward direction and as UCM (EN 81-20:2020, EN 81-50:2020) with reference to Lift Directive 2014/33/EU.

* Available performances for G-525 T2 and G-500 T2.

For diameters 360 ÷ 480, performances possible only for G-500 T2.



Tiro / Roping 1/1 · Corsa / Travel 30 mt						
Portata Duty load [kg]	Velocità Speed [m/s]	Puleggia Sheave [mm]	Combinazione funi Ropes combination	N° funi max Max ropes nr.	Peso cabina Cabin weight [kg]	
630	0,63 – 2,50	450	5÷6 x ø 11	10 x ø 11	850	1050
	0,63 – 2,50	480	4÷5 x ø 12	10 x ø 12		
	0,63 – 2,50	520*	4÷5 x ø 12/13	8 x ø 13		
	0,63 – 2,50	560*	4÷5 x ø 12/13	8 x ø 14		
	0,63 – 2,50	600*	4÷5 x ø 12/13	8 x ø 15		
800	0,63 – 2,50	360	7÷8 x ø 9	12 x ø 9	850	1200
	0,63 – 2,50	400	6÷7 x ø 10	12 x ø 10		
	0,63 – 2,50	450	5÷6 x ø 11	10 x ø 11		
	0,63 – 2,50	480	4÷5 x ø 12	10 x ø 12		
	0,63 – 2,50	520*	4÷5 x ø 12/13	8 x ø 13		
	0,63 – 2,50	560*	4÷5 x ø 12/13	8 x ø 14		
	0,63 – 2,50	600*	4÷5 x ø 12/13	8 x ø 15		
1000	0,63 – 2,50	360	9÷10 x ø 9	12 x ø 9	950	1250
	0,63 – 2,50	400	8÷9 x ø 10	12 x ø 10		
	0,63 – 2,50	450	7÷8 x ø 11	10 x ø 11		
	0,63 – 2,50	480	6÷7 x ø 12	10 x ø 12		
	0,63 – 2,50	520*	5÷6 x ø 13	8 x ø 13		
	0,63 – 2,50	560*	4÷5 x ø 13/14	8 x ø 14		
	0,63 – 2,50	600*	4÷5 x ø 14/15	8 x ø 15		
1250	0,63 – 2,50	360	10 x ø 9	12 x ø 9	1250	1500
	0,63 – 2,50	400	9 x ø 10	12 x ø 10		
	0,63 – 2,50	450	8÷9 x ø 11	10 x ø 11		
	0,63 – 2,50	480	7÷8 x ø 12	10 x ø 12		
	0,63 – 2,50	520*	6÷7 x ø 13	8 x ø 13		
1600	0,63 – 2,50	360	10÷12 x ø 9	12 x ø 9	1500	1800
	0,63 – 2,50	400	10÷12 x ø 10	12 x ø 10		

Tiro / Roping 2/1 · Corsa / Travel 30 mt						
Portata Duty load [kg]	Velocità Speed [m/s]	Puleggia Sheave [mm]	Combinazione funi Ropes combination	N° funi max Max ropes nr.	Peso cabina Cabin weight [kg]	
1000	0,63 – 2,50	400	4÷5 x ø 10	12 x ø 10	1100	1400
	0,63 – 2,50	450	4÷5 x ø 11	10 x ø 11		
	0,63 – 2,50	480	4÷5 x ø 11/12	10 x ø 12		
	0,63 – 2,50	520*	3÷4 x ø 13	8 x ø 13		
	0,63 – 2,50	560*	3÷4 x ø 13/14	8 x ø 14		
	0,63 – 2,50	600*	3÷4 x ø 14/15	8 x ø 15		
1250	0,63 – 2,50	360	5÷7 x ø 9	12 x ø 9	1250	1500
	0,63 – 2,50	400	4÷5 x ø 10	10 x ø 10		
	0,63 – 2,50	450	4÷5 x ø 11	10 x ø 11		
	0,63 – 2,50	480	4÷5 x ø 11/12	10 x ø 12		
	0,63 – 2,50	520*	3÷4 x ø 13	8 x ø 13		
	0,63 – 2,50	560*	3÷4 x ø 13/14	8 x ø 14		
	0,63 – 2,50	600*	3÷4 x ø 14/15	8 x ø 15		
	0,63 – 2,50	600*	3÷4 x ø 14/15	8 x ø 15		



Tiro / Roping 2/1 · Corsa / Travel 30 mt					
Portata Duty load [kg]	Velocità Speed [m/s]	Puleggia Sheave [mm]	Combinazione funi Ropes combination	N° funi max Max ropes nr.	Peso cabina Cabin weight [kg]
1600	0,63 – 2,50	360	5÷7 x ø 9	12 x ø 9	1500 1700
	0,63 – 2,50	400	4÷5 x ø 10	12 x ø 10	
	0,63 – 2,50	450	4÷5 x ø 11	10 x ø 11	
	0,63 – 2,50	480	4÷5 x ø 11/12	10 x ø 12	
	0,63 – 2,50	520*	3÷4 x ø 13	8 x ø 13	
	0,63 – 2,50	560*	3÷4 x ø 13/14	8 x ø 14	
	0,63 – 2,50	600*	3÷4 x ø 14/15	8 x ø 15	
2000	0,63 – 2,50	360	8 x ø 9	12 x ø 9	1800 2000
	0,63 – 2,50	400	6÷7 x ø 10	12 x ø 10	
	0,63 – 2,50	450	5÷6 x ø 11	10 x ø 11	
	0,63 – 2,50	480	5÷6 x ø 11/12	10 x ø 12	
	0,63 – 2,50	520*	5 x ø 13	8 x ø 13	
	0,63 – 2,50	560*	5 x ø 13/14	8 x ø 14	
	0,63 – 2,50	600*	5 x ø 14/15	8 x ø 15	
2500	0,63 – 2,50	360	10 x ø 9	12 x ø 9	2500 3000
	0,63 – 2,50	400	8÷9 x ø 10	12 x ø 10	
	0,63 – 2,50	450	7÷8 x ø 11	10 x ø 11	
	0,63 – 2,50	480	7÷8 x ø 11/12	10 x ø 12	
	0,63 – 2,50	520*	6÷7 x ø 13	8 x ø 13	

Tiro / Roping 4/1 · Corsa / Travel 30 mt					
Portata Duty load [kg]	Velocità Speed [m/s]	Puleggia Sheave [mm]	Combinazione funi Ropes combination	N° funi max Max ropes nr.	Peso cabina Cabin weight [kg]
5000	0,63 – 1,00	360	10 x ø 9	12 x ø 9	4500 6000
	0,63 – 1,00	400	8÷9 x ø 10	12 x ø 10	
	0,63 – 1,00	450	7÷8 x ø 11	10 x ø 11	
	0,63 – 1,00	480	7÷8 x ø 11/12	10 x ø 12	
	0,63 – 1,00	520*	6÷7 x ø 13	8 x ø 13	

Altre combinazioni a richiesta. / Additional combination on request.

* Available performances for G-525 and G-500.

For diameters 360 ÷ 480, performances possible only for G-500.



TELMO Dati generali / General data



TelMo (Tiro/Roping 1/1)

Kit telaio per modernizzazioni con gearless
G-200 · G-300 · G-400
Frame-Set for modernisation with gearless
G-200 · G-300 · G-400

Tabella riassuntiva configurazioni standard G-200 · G-300 / Chart with Standard configurations G-200 · G-300

Portata Duty load [kg]	Macchina Machine	Ø Trazione Traction unit [mm]	Ø Rinvii Divertors [mm]	Calata funi 1/1 Dist. betw ropes 1/1 lmax [mm]	Max carico statico Max static load [kg]
225	G-200 T1	160	240	450-1020	2500
225	G-200 T1	210	240	450-1020	2500
320	G-200 T1	160	240	450-1020	2500
320	G-300 T0	160	240	450-1020	2750
320	G-300 T0	210	240	450-1020	2750
320	G-300 T0	240	240	450-1020	2750
320	G-300 T1	320	320	415-970	2750
450	G-300 T0	160	240	450-1020	2750
450	G-300 T0	210	240	450-1020	2750
450	G-300 T1	240	240	450-1020	2750
450	G-300 T2	320	320	415-970	2750
630	G-300 T0	160	240	450-1020	2750
630	G-300 T1	210	240	450-1020	2750
630	G-300 T2	240	240	450-1020	2750
800	G-300 T1	160	240	450-1020	2750
800	G-300 T2	210	240	450-1020	2750

Ø Max pulegge = 320 mm / Max sheaves Ø = 320 mm

Tabella riassuntiva configurazioni standard G-400 / Chart with Standard configurations G-400

Portata Duty load [kg]	Macchina Machine	Ø Trazione Traction unit [mm]	Ø Rinvii Divertors [mm]	Calata funi 1/1 Dist. betw ropes 1/1 lmax [mm]	Max carico statico Max static load [kg]
480	G-400 T1	400	400	500-1000	3500
630	G-400 T1	320	320	430-1040	3500
630	G-400 T2	400	400	500-1000	4500
800	G-400 T3	400	400	500-1000	5200
1000	G-400 T3	400	400	500-1000	5200
1250	G-400 T3	320	320	430-1040	5200

Ø Max pulegge = 400 mm / Max sheaves Ø = 400 mm

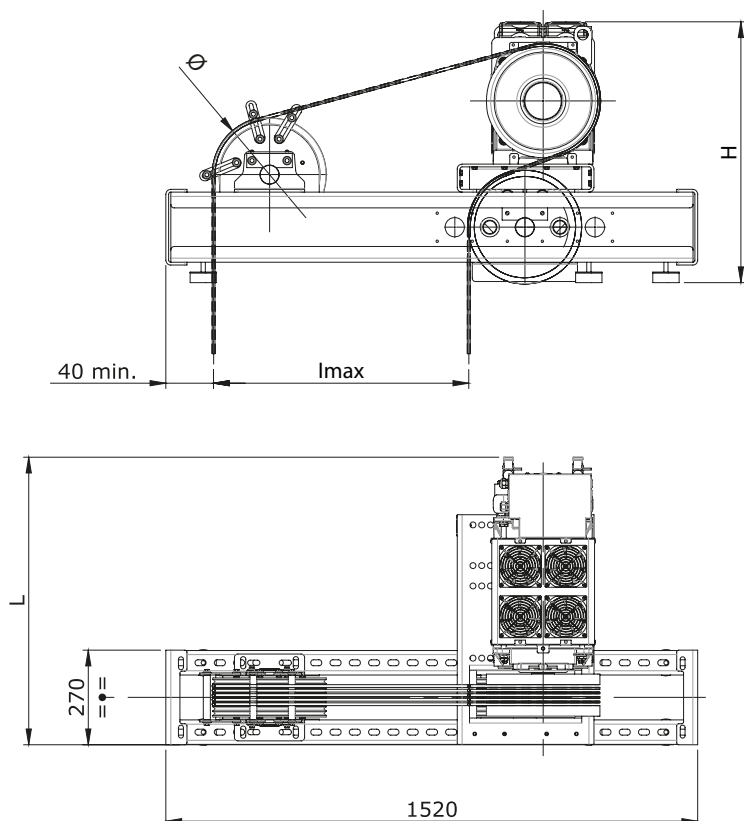

**TELMO**Kit telaio per modernizzazioni con gearless
Frame-Set for modernisation with gearless**G-200 - G-300 Tiro 1/1 / Roping 1/1****Dimensioni / Dimensions [mm]**

Macchina Machine	Ø	L	H
G-200 T1	240÷320	655	745
G-300 T0	240÷320	696	745
G-300 T1	240÷320	813	745
G-300 T2	240÷320	845	745

lmax Vedi tabella di pagina precedente.
See charts on the previous page.

Flessione inversa possibile solo con funi metalliche ad alta resistenza. Con funi ricoperte, dimensioni della calata funi disponibili a richiesta.

Reverse bending only possible with metallic high resistance ropes. With coated ropes the distance between ropes is available on request.

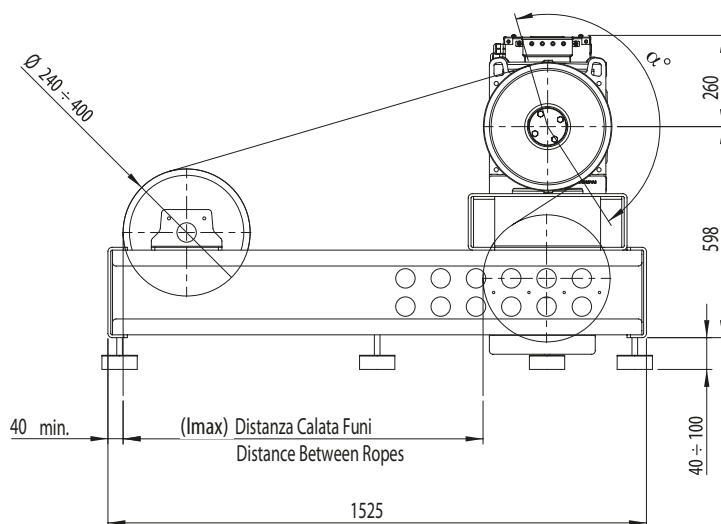
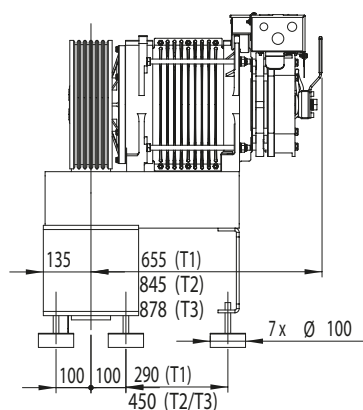
G-400 Tiro 1/1 / Roping 1/1**Dimensioni / Dimensions**

Ø [mm]	* lmax [mm]	α° Min.
240	1180	126°
320	1040	156°
360	1020	164°
400	1000	179°

* Valori lmax definiti con stessi diametri per trazione e rinvi.
lmax values defined with the same diameters for traction sheave and divertors.



GEARLESS

| TELMO |

ALBERTO SASSI

67



G-300T1 · T2 Telaio alto + deviazione per modernizzazioni / High frame + divertor unit for modernisations

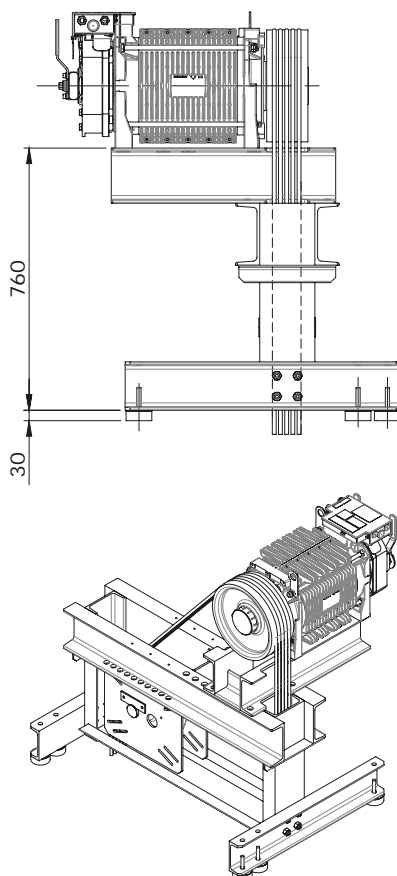
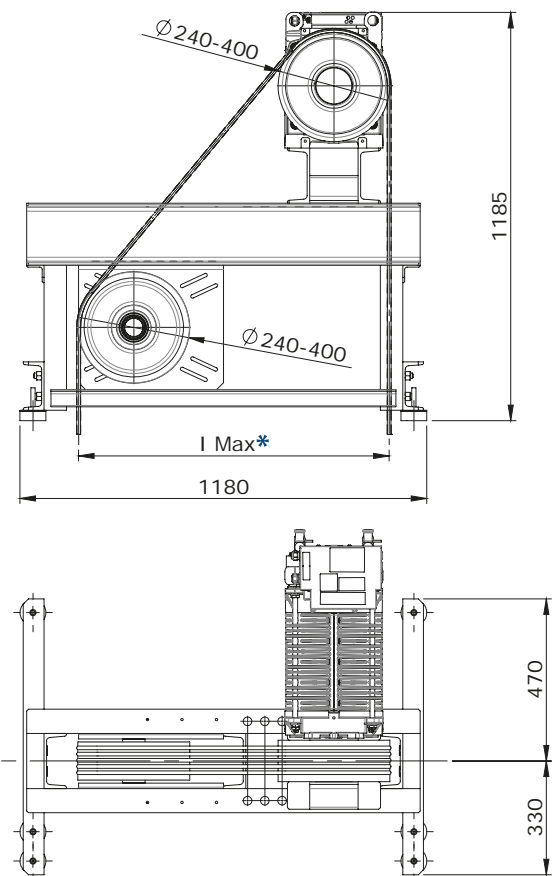

Dimensioni / Dimensions [mm]

Pulegge Ø Sheaves Ø	*Imax
Ø 240	850
Ø 320	890
Ø 360	860
Ø 400	900

G-400T1 Telaio piano / Flat frame

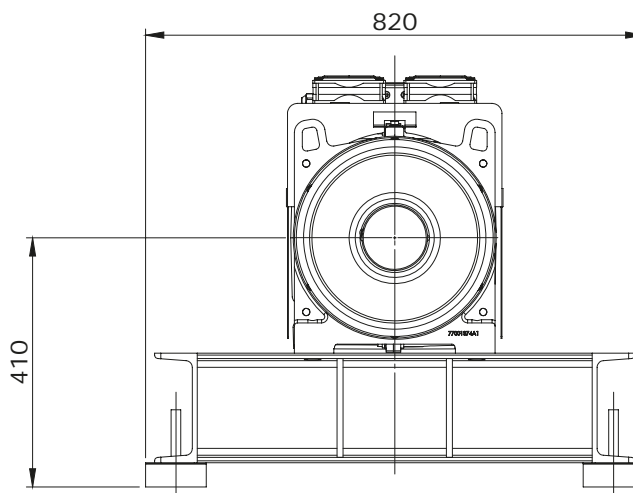
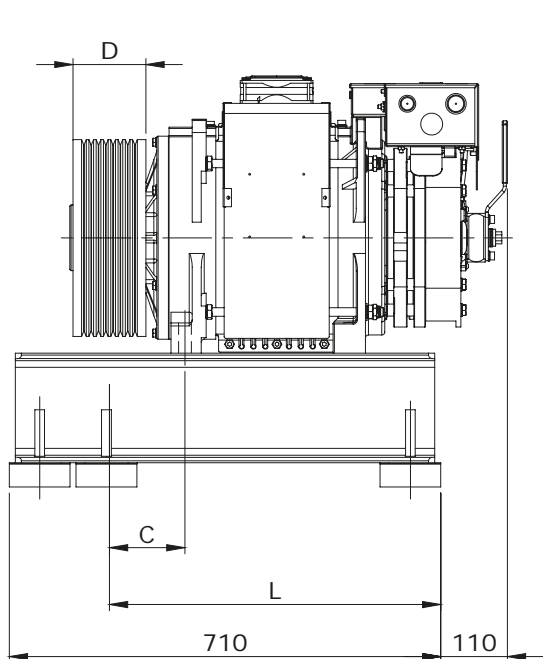

Dimensioni / Dimensions [mm]

D	C	L
120	124	545
150	139	560



G-400 T2 · T3 Telaio piano / Flat frame

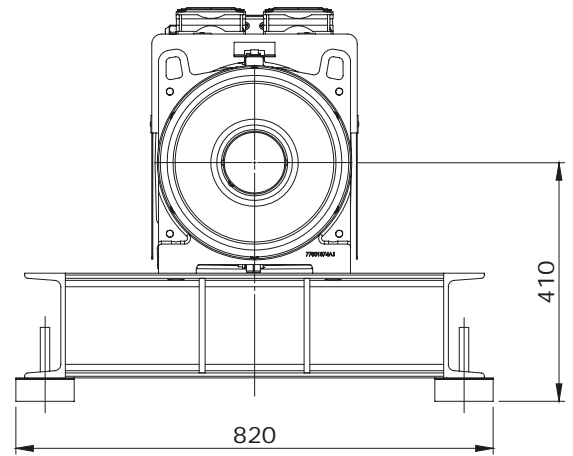
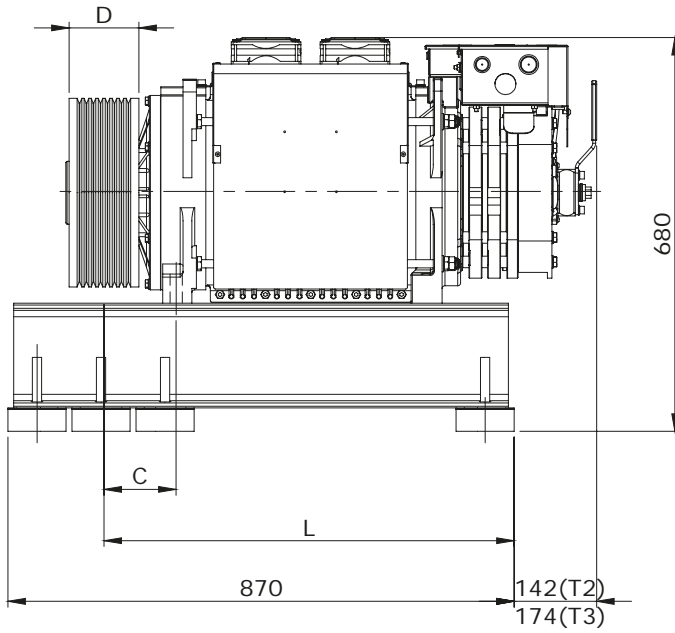

Dimensioni / Dimensions [mm]

D	C	L
120	124	705
150	139	720

G-400 in nicchia / niche Telaio piano per modernizzazioni / Flat frame for modernisation

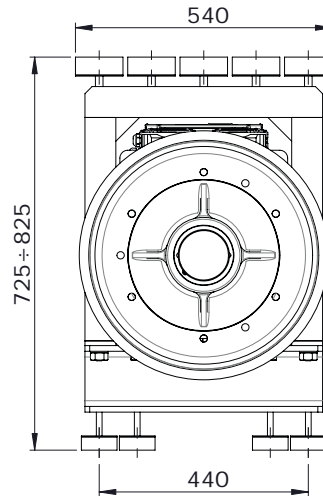
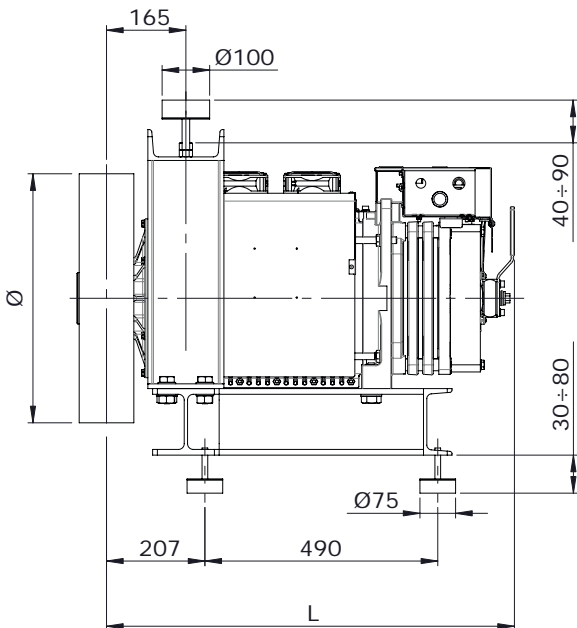

Dimensioni / Dimensions [mm]

Macchina Machine	Ø	L
G-400 T1	210-600	654
G-400 T2	240-600	824
G-400 T3	240-600	878

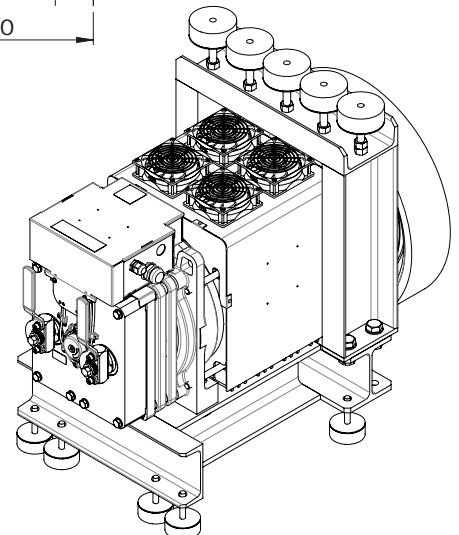

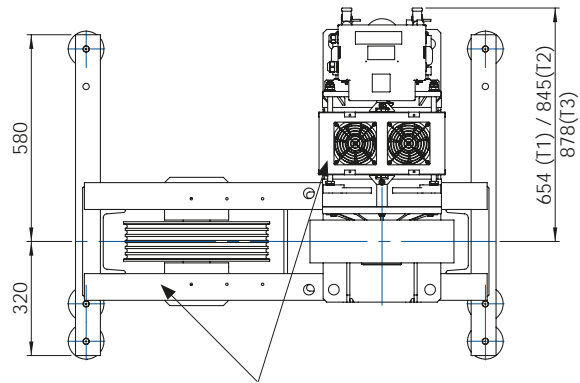
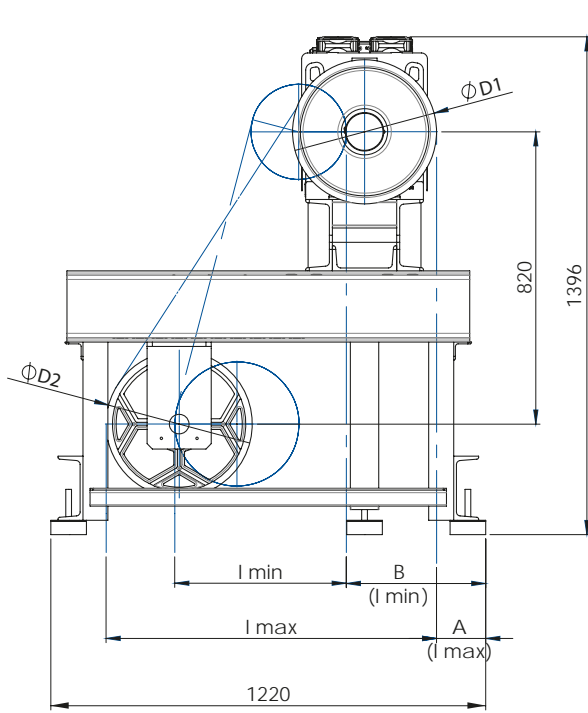

Posizione reversibile della macchina (telaio smontabile)
Dual Position of the machine (demontable frame)

Dimensioni / Dimensions [mm]

D1	D2*	l _{min} ÷ l _{max}		A	B
Ø240	Ø240	405	850	220	290
Ø320	Ø320	485	890	180	250
Ø360	Ø360	525	910	160	230
Ø400	Ø400	565	930	140	210
Ø450	Ø450	615	890	185	185
Ø480	Ø480/500	645	905	170	170
Ø520	Ø480/500	665	925	150	150

* Ø Esemplativo: possibili altre combinazioni di rinvio.
Ø for example: others divertor sheave combinatios available.

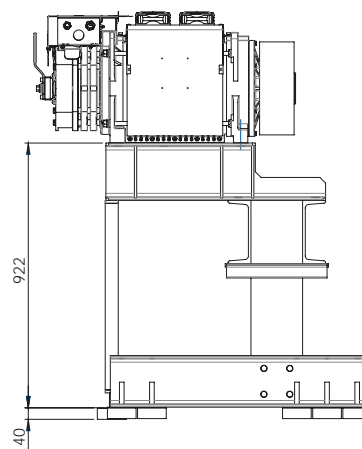
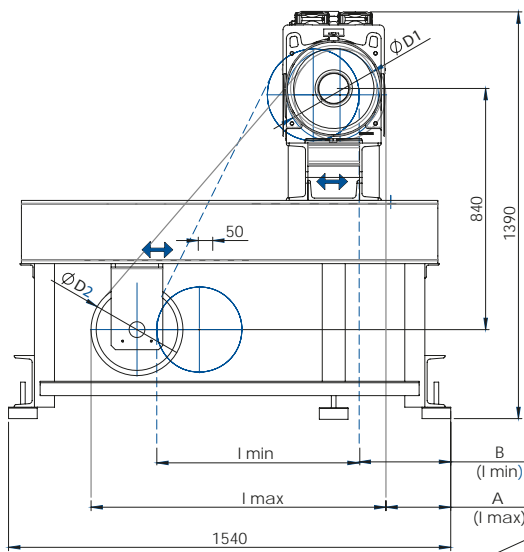

Posizione reversibile della macchina (telaio smontabile)
Dual Position of the machine (demontable frame)

Dimensioni / Dimensions [mm]

D1	D2*	l _{min} ÷ l _{max}		A	B
Ø240	Ø240	625	1100	205	340
Ø320	Ø320	705	1180	165	300
Ø360	Ø360	745	1220	145	280
Ø400	Ø400	785	1260	125	260
Ø450	Ø450	810	1210	168	235
Ø480	Ø480/500	825	1230	155	220
Ø520		845	1250	135	200
Ø560		865	1200	180	180
Ø600		885	1220	160	160
Ø650		910	1250	140	140

* Ø Esemplativo: possibili altre combinazioni di rinvio.
Ø for example: others divertor sheave combinatios available.

G-500T1 Telaio piano / Flat frame

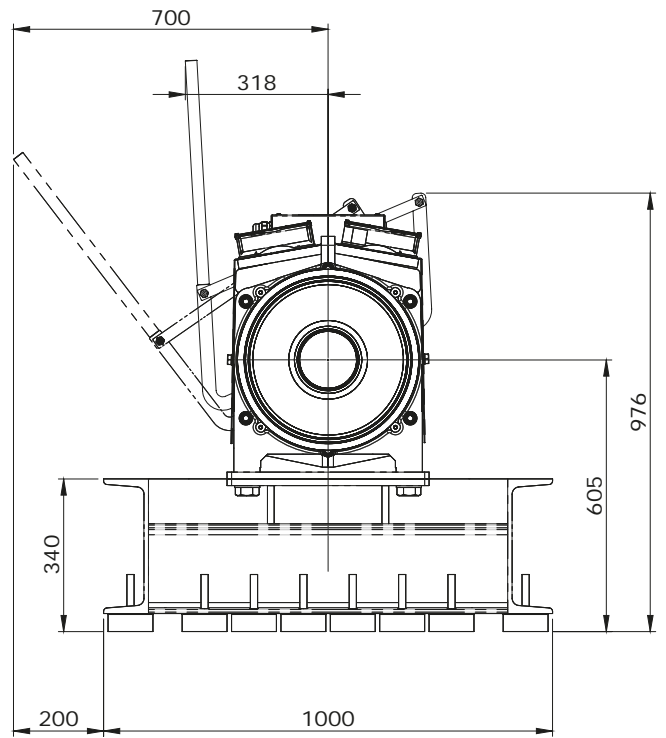
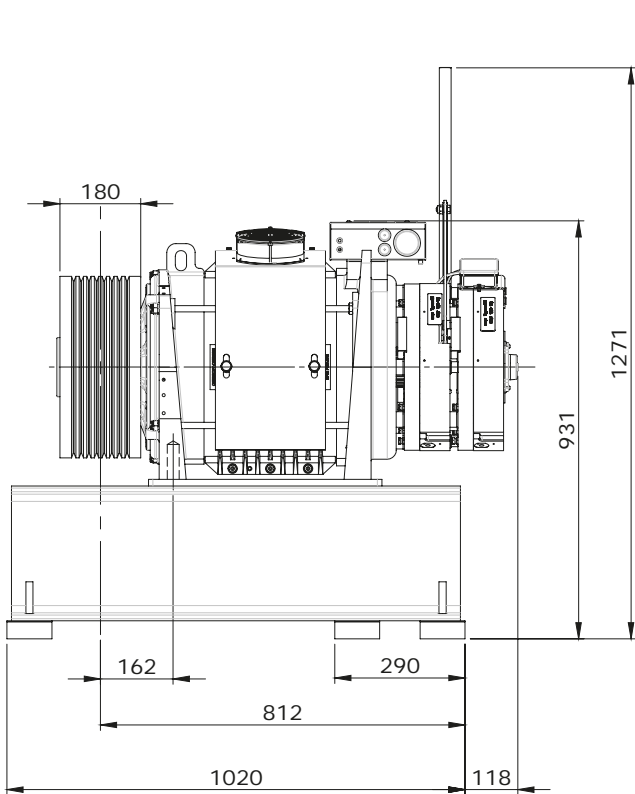

G-500T2 Telaio piano / Flat frame

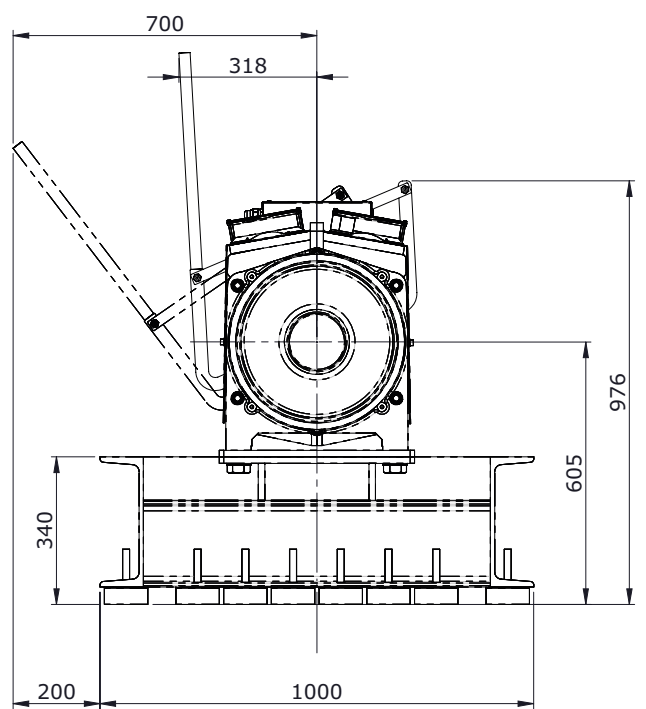
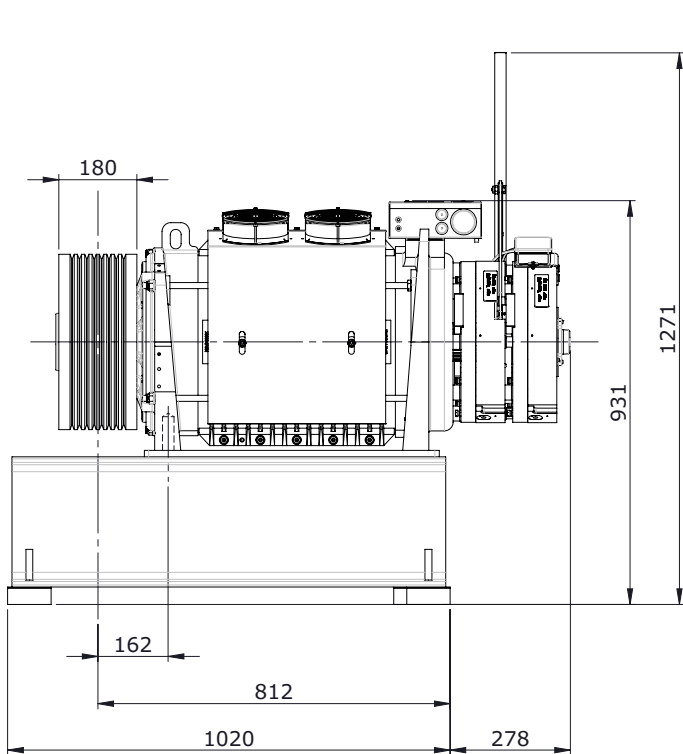

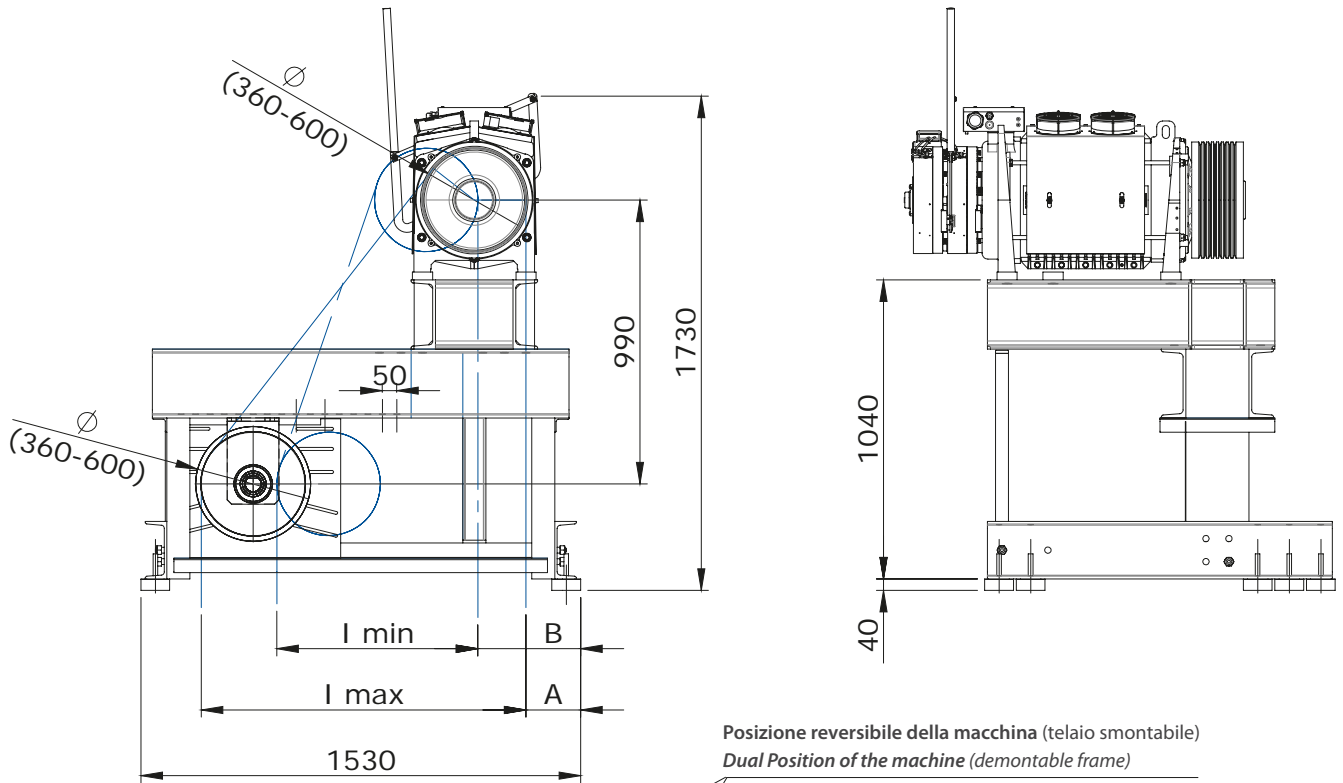

Dimensioni / Dimensions [mm]

D1	D2*	Imin + Imax		A	B
Ø 360	Ø 360	530	1250	190	340
Ø 400	Ø 400	570	1260	170	320
Ø 450	Ø 450	620	1265	145	295
Ø 480	Ø 480/500	650	1270	130	280
Ø 520	Ø 520/550	690	1230	185	185
Ø 560		710	1200	165	240
Ø 600		730	1160	145	220

* Ø Esemplativo: possibili altre combinazioni di rinvio.
 Ø for example: others divertor sheave combinatios available.

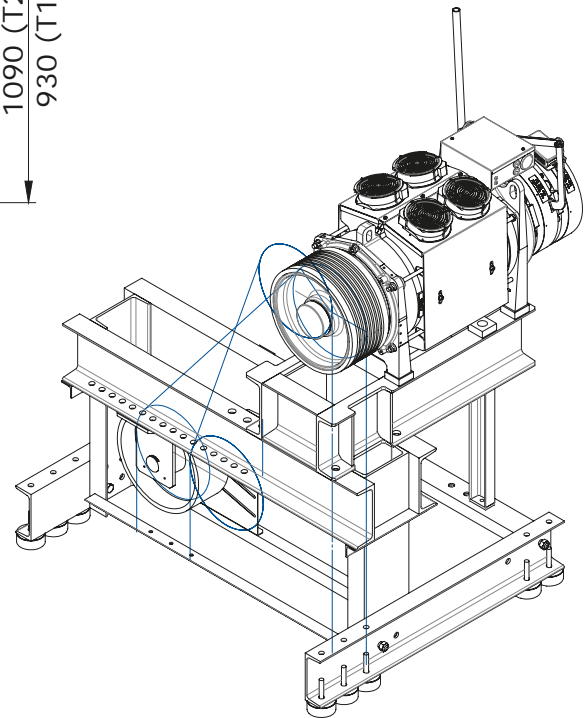



SCHEDE ELETTRONICHE / ELECTRONIC BOARDS

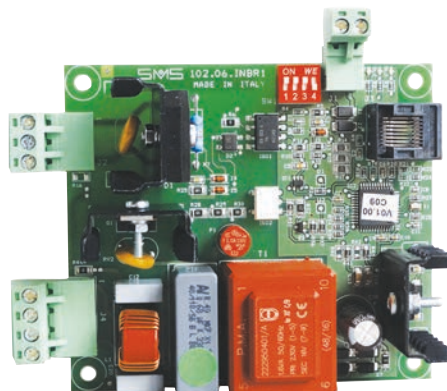

ECOBRAKE

Scheda elettronica che, dopo un tempo iniziale, riduce la tensione di alimentazione al valore di mantenimento
Electronic board that, after an initial time, reduces power voltage at the maintenance value

Alimentatore / Power supply

Scheda elettronica che fornisce il corretto valore di tensione continua al freno elettromagnetico
Electronic board that provides the correct value continuous voltage to the electromagnetic brake

	ECOBRAKE	ALIMENTATORE / POWER SUPPLY	
Dimensione e peso <i>Dimension and weight</i>	146 x 104 x 42 mm 450 g circa / <i>approximately</i>	100 x 88 x 35 mm 450 g circa / <i>approximately</i>	146 x 104 x 42 mm 450 g circa / <i>approximately</i>
Tensione di ingresso / <i>Input voltage</i>	220 ÷ 240 V AC ± 10%		
Tensione in uscita / <i>Output voltage</i>	48 ÷ 205 V DC	50 ÷ 205 V DC	48 ÷ 205 V DC
Corrente di uscita / <i>Output current</i>	max 5 A	max 3 A	max 5 A



TABELLA ACCESSORI / ACCESSORIES TABLE

ACCESSORI GEARLESS / <i>GEARLESS ACCESSORIES</i>	G-200	G-300	G-400	G-500	G-525
INVERTER / <i>INVERTER</i>	+	+	+	+	+
ENCODER / <i>ENCODER</i>	✓	✓	✓	✓	✓
CAVI ALIMENTAZIONE MOTORE / <i>CABLE FOR MOTOR SUPPLY</i>	+	+	+	+	+
CARTER PULEGGIA / <i>CARTER FOR SHEAVE</i>	+	+	+	+	+
ANTINTRUSIONE / <i>ANTI-INTRUSION</i>	✓	✓	✓	✓	✓
TEMpra PULEGGIA / <i>SHEAVE TREATMENT</i>	✓ +	✓ +	✓ +	+	+
LEVE APERTURA MANUALE FRENO / <i>LEVERS FOR BRAKE HAND RELEASE</i>	+	+	+	+	✓
VENTILAZIONE FORZATA / <i>FORCED VENTILATION</i>	✓ +	✓ +	✓ +	✓ +	✓ +
ECOBRAKE / <i>ECOBRAKE</i>	+	+	+	+	+
TELAIO PIANO CON DEVIAZIONE / <i>FLAT FRAME WITH DIVERTER</i>	+	+	+	+	+
TELAIO ALTO CON DEVIAZIONE / <i>HIGH FRAME WITH DIVERTER</i>	+	+	+	+	+
TELMO (KIT TELAIO PER MODERNIZZAZIONI / <i>FRAME SET FOR MODERNISATION</i>)	+	+	+	✗	✗
ANTIVIBRANTI / <i>VIBRATION DAMPERS</i>	+	+	+	+	+
PIASTRA DI INTERFACCIA PER MODERNIZZAZIONI <i>INTERFACE PLATE SUITABLE FOR MODERNIZATIONS</i>	+	+	+	✗	✗

✓ DI SERIE / *STANDARD*

+ A RICHIESTA / *ON REQUEST*

✗ NON DISPONIBILE / *NOT AVAILABLE*





Azienda con sistema di gestione qualità
certificata da **TÜV ITALIA Srl** secondo la
norma ISO 9001

Alberto Sassi S.p.A.
(Gruppo Sassi Holding)

Via Guido Rossa 1, Località Crespellano
40053 Valsamoggia (BO), Italia
Tel. +39 051 672 02 02

Ufficio commerciale / Sales Department
email: sales@sassi.it - fax: +39 051 6720244

Ufficio Assistenza post vendita / After Sales Department
email: aftersales@sassi.it - fax: +39 051 969468

Ufficio Tecnico / Technical Department
email: tech@sassi.it - fax: +39 051 6720136

Per ordini / For orders
email: sales@sassi.it

www.sassi.it

